

# RMC-8357

## User Manual

Worldwide Technical Support and Product Information

[ni.com](http://ni.com)

#### Worldwide Offices

Visit [ni.com/niglobal](http://ni.com/niglobal) to access the branch office websites, which provide up-to-date contact information, support phone numbers, email addresses, and current events.

#### National Instruments Corporate Headquarters

11500 North Mopac Expressway Austin, Texas 78759-3504 USA Tel: 512 683 0100

For further support information, refer to the *NI Services* appendix. To comment on NI documentation, refer to the NI website at [ni.com/info](http://ni.com/info) and enter the Info Code `feedback`.

© 2017 National Instruments. All rights reserved.

# Legal Information

---

## Limited Warranty

This document is provided 'as is' and is subject to being changed, without notice, in future editions. For the latest version, refer to [ni.com/manuals](http://ni.com/manuals). NI reviews this document carefully for technical accuracy; however, NI MAKES NO EXPRESS OR IMPLIED WARRANTIES AS TO THE ACCURACY OF THE INFORMATION CONTAINED HEREIN AND SHALL NOT BE LIABLE FOR ANY ERRORS.

NI warrants that its hardware products will be free of defects in materials and workmanship that cause the product to fail to substantially conform to the applicable NI published specifications for one (1) year from the date of invoice.

For a period of ninety (90) days from the date of invoice, NI warrants that (i) its software products will perform substantially in accordance with the applicable documentation provided with the software and (ii) the software media will be free from defects in materials and workmanship.

If NI receives notice of a defect or non-conformance during the applicable warranty period, NI will, in its discretion: (i) repair or replace the affected product, or (ii) refund the fees paid for the affected product. Repaired or replaced Hardware will be warranted for the remainder of the original warranty period or ninety (90) days, whichever is longer. If NI elects to repair or replace the product, NI may use new or refurbished parts or products that are equivalent to new in performance and reliability and are at least functionally equivalent to the original part or product.

You must obtain an RMA number from NI before returning any product to NI. NI reserves the right to charge a fee for examining and testing Hardware not covered by the Limited Warranty.

This Limited Warranty does not apply if the defect of the product resulted from improper or inadequate maintenance, installation, repair, or calibration (performed by a party other than NI); unauthorized modification; improper environment; use of an improper hardware or software key; improper use or operation outside of the specification for the product; improper voltages; accident, abuse, or neglect; or a hazard such as lightning, flood, or other act of nature.

THE REMEDIES SET FORTH ABOVE ARE EXCLUSIVE AND THE CUSTOMER'S SOLE REMEDIES, AND SHALL APPLY EVEN IF SUCH REMEDIES FAIL OF THEIR ESSENTIAL PURPOSE.

EXCEPT AS EXPRESSLY SET FORTH HEREIN, PRODUCTS ARE PROVIDED "AS IS" WITHOUT WARRANTY OF ANY KIND AND NI DISCLAIMS ALL WARRANTIES, EXPRESSED OR IMPLIED, WITH RESPECT TO THE PRODUCTS, INCLUDING ANY IMPLIED WARRANTIES OF MERCHANTABILITY, FITNESS FOR A PARTICULAR PURPOSE, TITLE OR NON-INFRINGEMENT, AND ANY WARRANTIES THAT MAY ARISE FROM USAGE OF TRADE OR COURSE OF DEALING. NI DOES NOT WARRANT, GUARANTEE, OR MAKE ANY REPRESENTATIONS REGARDING THE USE OF OR THE RESULTS OF THE USE OF THE PRODUCTS IN TERMS OF CORRECTNESS, ACCURACY, RELIABILITY, OR OTHERWISE. NI DOES NOT WARRANT THAT THE OPERATION OF THE PRODUCTS WILL BE UNINTERRUPTED OR ERROR FREE.

In the event that you and NI have a separate signed written agreement with warranty terms covering the products, then the warranty terms in the separate agreement shall control.

## Copyright

Under the copyright laws, this publication may not be reproduced or transmitted in any form, electronic or mechanical, including photocopying, recording, storing in an information retrieval system, or translating, in whole or in part, without the prior written consent of National Instruments Corporation.

National Instruments respects the intellectual property of others, and we ask our users to do the same. NI software is protected by copyright and other intellectual property laws. Where NI software may be used to reproduce software or other materials belonging to others, you may use NI software only to reproduce materials that you may reproduce in accordance with the terms of any applicable license or other legal restriction.

## End-User License Agreements and Third-Party Legal Notices

You can find end-user license agreements (EULAs) and third-party legal notices in the following locations:

- Notices are located in the <National Instruments>\\_Legal Information and <National Instruments> directories.
- EULAs are located in the <National Instruments>\Shared\MDF\Legal\license directory.
- Review <National Instruments>\\_Legal Information.txt for information on including legal information in installers built with NI products.

## U.S. Government Restricted Rights

If you are an agency, department, or other entity of the United States Government ("Government"), the use, duplication, reproduction, release, modification, disclosure or transfer of the technical data included in this manual is governed by the Restricted Rights provisions under Federal Acquisition Regulation 52.227-14 for civilian agencies and Defense Federal Acquisition Regulation Supplement Section 252.227-7014 and 252.227-7015 for military agencies.

## Trademarks

Refer to the *NI Trademarks and Logo Guidelines* at [ni.com/trademarks](http://ni.com/trademarks) for more information on NI trademarks.

ARM, Keil, and  $\mu$ Vision are trademarks or registered of ARM Ltd or its subsidiaries.

LEGO, the LEGO logo, WEDO, and MINDSTORMS are trademarks of the LEGO Group.

TETRIX by Pitsco is a trademark of Pitsco, Inc.

FIELDBUS FOUNDATION™ and FOUNDATION™ are trademarks of the Fieldbus Foundation.

EtherCAT® is a registered trademark of and licensed by Beckhoff Automation GmbH.

CANopen® is a registered Community Trademark of CAN in Automation e.V.

DeviceNet™ and EtherNet/IP™ are trademarks of ODVA.

Go!, SensorDAQ, and Vernier are registered trademarks of Vernier Software & Technology. Vernier Software & Technology and [vernier.com](http://vernier.com) are trademarks or trade dress.

Xilinx is the registered trademark of Xilinx, Inc.

Taptite and Trilobular are registered trademarks of Research Engineering & Manufacturing Inc.

FireWire® is the registered trademark of Apple Inc.

Linux® is the registered trademark of Linus Torvalds in the U.S. and other countries.

Handle Graphics®, MATLAB®, Simulink®, Stateflow®, and xPC TargetBox® are registered trademarks, and Simulink Coder™, TargetBox™, and Target Language Compiler™ are trademarks of The MathWorks, Inc.

Tektronix®, Tek, and Tektronix, Enabling Technology are registered trademarks of Tektronix, Inc.

The Bluetooth® word mark is a registered trademark owned by the Bluetooth SIG, Inc.

The ExpressCard™ word mark and logos are owned by PCMCIA and any use of such marks by National Instruments is under license.

The mark LabWindows is used under a license from Microsoft Corporation. Windows is a registered trademark of Microsoft Corporation in the United States and other countries.

Other product and company names mentioned herein are trademarks or trade names of their respective companies.

Members of the National Instruments Alliance Partner Program are business entities independent from NI and have no agency, partnership, or joint-venture relationship with NI.

## Patents

For patents covering NI products/technology, refer to the appropriate location: **Help»Patents** in your software, the `patents.txt` file on your media, or the *National Instruments Patent Notice* at [ni.com/patents](http://ni.com/patents).

## Export Compliance Information

Refer to the *Export Compliance Information* at [ni.com/legal/export-compliance](http://ni.com/legal/export-compliance) for the NI global trade compliance policy and how to obtain relevant HTS codes, ECCNs, and other import/export data.

## WARNING REGARDING USE OF NATIONAL INSTRUMENTS PRODUCTS

YOU ARE ULTIMATELY RESPONSIBLE FOR VERIFYING AND VALIDATING THE SUITABILITY AND RELIABILITY OF THE PRODUCTS WHENEVER THE PRODUCTS ARE INCORPORATED IN YOUR SYSTEM OR APPLICATION, INCLUDING THE APPROPRIATE DESIGN, PROCESS, AND SAFETY LEVEL OF SUCH SYSTEM OR APPLICATION.

PRODUCTS ARE NOT DESIGNED, MANUFACTURED, OR TESTED FOR USE IN LIFE OR SAFETY CRITICAL SYSTEMS, HAZARDOUS ENVIRONMENTS OR ANY OTHER ENVIRONMENTS REQUIRING FAIL-SAFE PERFORMANCE, INCLUDING IN THE OPERATION OF NUCLEAR FACILITIES; AIRCRAFT NAVIGATION; AIR TRAFFIC CONTROL SYSTEMS; LIFE SAVING OR LIFE SUSTAINING SYSTEMS OR SUCH OTHER MEDICAL DEVICES; OR ANY OTHER APPLICATION IN WHICH THE FAILURE OF THE PRODUCT OR SERVICE COULD LEAD TO DEATH, PERSONAL INJURY, SEVERE PROPERTY DAMAGE OR ENVIRONMENTAL HARM (COLLECTIVELY, "HIGH-RISK USES"). FURTHER, PRUDENT STEPS MUST BE TAKEN TO PROTECT AGAINST FAILURES, INCLUDING PROVIDING BACK-UP AND SHUT-DOWN MECHANISMS. NI EXPRESSLY DISCLAIMS ANY EXPRESS OR IMPLIED WARRANTY OF FITNESS OF THE PRODUCTS OR SERVICES FOR HIGH-RISK USES.

# Contents

---

## About This Manual

Related Documentation .....	xiii
-----------------------------	------

## Chapter 1

### Getting Started

Unpacking.....	1-1
What You Need to Get Started .....	1-1
RMC-8357 Overview .....	1-2
Key Features .....	1-2
Mainboard Features .....	1-2
CPU .....	1-2
Memory .....	1-2
Slots .....	1-2
Video .....	1-2
HDD.....	1-2
Blu-ray.....	1-3
Onboard LAN .....	1-3
Onboard I/O.....	1-3
Power Supply.....	1-3
Power Management Features.....	1-3
Front Panel LEDs .....	1-3
System Management.....	1-3
RMC-8357 Description .....	1-4

## Chapter 2

### Installation and BIOS Setup

Safety Information .....	2-1
Chassis Cooling Considerations .....	2-2
Providing Adequate Clearance .....	2-2
Installation .....	2-2
Connecting Safety Ground .....	2-3
Connecting to Power Source .....	2-3
BIOS Setup .....	2-3
Starting the BIOS Setup Utility .....	2-4
How to Change the Configuration Data .....	2-4
How to Start the Setup Utility .....	2-4
Main Setup.....	2-5
System Date/System Time.....	2-5
BIOS Version .....	2-5
Build Date.....	2-5

Memory Information.....	2-5
Total Memory .....	2-5
Memory Speed .....	2-5
Advanced Setup Configurations .....	2-5
Boot Feature.....	2-6
Quiet Boot.....	2-6
AddOn ROM Display Mode.....	2-6
Bootup NumLock State .....	2-6
Wait For F1 If Error .....	2-6
INT19 (Interrupt 19) Trap Response .....	2-6
Re-try Boot .....	2-6
Power Configuration.....	2-6
DeepSx Power Policies .....	2-6
Watch Dog Function .....	2-7
Power Button Function .....	2-7
Restore on AC Power Loss.....	2-7
Chipset Configuration.....	2-7
CPU Configuration .....	2-7
Clock Spread Spectrum .....	2-8
Hyper-Threading.....	2-8
Performance/Watt .....	2-8
Execute Disable Bit .....	2-8
PPIN Control.....	2-8
Hardware Prefetcher .....	2-8
Adjacent Cache Line Prefetch .....	2-8
DCU Streamer Prefetcher .....	2-9
DCU IP Prefetcher.....	2-9
DCU (Data Cache Unit) Mode .....	2-9
Direct Cache Access (DCA) .....	2-9
DCA Prefetch Delay .....	2-9
X2APIC (Extended Advanced Programmable Interrupt Controller) .....	2-9
AES-NI .....	2-9
Intel Virtualization Technology.....	2-10
Advanced Power Management Configuration.....	2-10
Power Technology .....	2-10
Config TDP .....	2-10
CPU P State Control .....	2-10
EIST (P-State).....	2-10
Turbo Mode .....	2-10
P-state Coordination .....	2-10
CPU C State Control.....	2-10
CPU C3 Report.....	2-11
CPU C6 Report.....	2-11
Enhanced Halt State (C1E).....	2-11

CPU T State Control.....	2-11
ACPI (Advanced Configuration Power Interface) T-States .....	2-11
Socket RAPL (Running Average Power Limit) Configuration.....	2-11
FAST-RAPL-NSTRIKE-PL2-DUTY-CYCLE .....	2-11
Turbo Power Limit Lock .....	2-11
Long Power Limit Override .....	2-11
Long Duration Power Limit .....	2-11
Package Clamping Limit1 .....	2-12
Short Duration Power Limit Enable .....	2-12
Short Duration Power Limit .....	2-12
Package Clamping Limit2 .....	2-12
Chipset Configuration.....	2-12
North Bridge .....	2-12
IIO Configuration .....	2-12
EV DFX (Device Function On-Hide) Feature .....	2-12
IIO1 Configuration/IIO2 Configuration .....	2-12
IOAT Configuration .....	2-13
Enable I/OAT .....	2-13
No Snoop .....	2-13
Relaxed Ordering.....	2-13
Intel VT for Directed I/O (VT-d) .....	2-14
Interrupt Remapping.....	2-14
Coherency Support (Non-Isoch).....	2-14
Coherency Support (Isoch).....	2-14
QPI (Quick Path Interconnect) Configuration.....	2-14
QPI Status .....	2-14
Link Speed Mode.....	2-14
Link Frequency Select .....	2-14
Link L0p Enable .....	2-15
Link L1 Enable .....	2-15
Isoc Mode .....	2-15
Memory Configuration.....	2-15
Enforce POR.....	2-15
Memory Frequency.....	2-15
ECC Support .....	2-15
Data Scrambling .....	2-15
Enable ADR.....	2-15
DRAM RAPL (Running Average Power Limit) Baseline .....	2-15
Set Throttling Mode.....	2-16
Socket Interleave Below 4GB .....	2-16
Channel Interleaving.....	2-16
Rank Interleaving .....	2-16
A7 Mode .....	2-16
DIMM Information.....	2-16

- Memory RAS (Reliability\_Availability\_Serviceability) Configuration..... 2-16
  - RAS Mode ..... 2-16
  - Lockstep x4 DIMMs..... 2-17
  - Memory Rank Sparing..... 2-17
  - Patrol Scrub..... 2-17
  - Patrol Scrub Interval ..... 2-17
  - Demand Scrub..... 2-17
  - Device Tagging..... 2-17
- South Bridge ..... 2-17
  - Legacy USB Support ..... 2-17
  - XHCI Hand-Off..... 2-18
  - EHCI Hand-Off..... 2-18
  - USB Mass Storage Driver Support..... 2-18
  - Port 60/64 Emulation ..... 2-18
  - USB 3.0 Support..... 2-18
  - EHCI1 ..... 2-18
  - EHCI2 ..... 2-18
  - XHCI Pre-Boot Drive ..... 2-18
  - XHCI Idle L1 ..... 2-18
  - PCH DMI ASPM..... 2-18
- SATA Configuration..... 2-19
  - SATA Controller..... 2-19
  - Configure SATA as ..... 2-19
- sSATA Configuration ..... 2-21
  - sSATA Controller ..... 2-21
  - Configure sSATA as..... 2-21
- Server ME (Management Engine) Configuration..... 2-23
- PCIe/PCI/PnP Configuration ..... 2-23
  - PCI AER (Advanced Error-Reporting) Support..... 2-23
  - VGA Palette Snoop..... 2-23
  - PERR# Generation Support..... 2-23
  - SERR# Generation Support..... 2-24
  - Above 4G Decoding ..... 2-24
  - SR-IOV Support ..... 2-24
  - Maximum Payload..... 2-24
  - Maximum Read Request..... 2-24
  - ASPM Support ..... 2-24
  - MMIOHBase ..... 2-24
  - MMIO High Size ..... 2-24
  - Onboard LAN OPROM..... 2-25
  - VGA Priority..... 2-25
  - Network Stack..... 2-25
  - Ipv6 PXE Support ..... 2-25



Super IO Configuration .....	2-25
Serial Port 1 Configuration/Serial Port 2 Configuration .....	2-25
Device Settings .....	2-25
Change Port 1 Settings/Change Port 2 Settings.....	2-25
Serial Port 2 Attribute .....	2-26
Serial Port Console Redirection .....	2-26
COM 1 Console Redirection .....	2-26
COM1 Console Redirection .....	2-26
SOL/COM2 Console Redirection.....	2-28
SOL/COM2 Console Redirection Settings.....	2-28
EMS Console Redirection Settings .....	2-30
Trusted Computing .....	2-30
Configuration.....	2-30
ACPI Settings .....	2-31
WHEA Support.....	2-31
Event Logs.....	2-31
Change SMBIOS Event Log Settings .....	2-31
Enabling/Disabling Options .....	2-31
SMBIOS Event Log.....	2-31
Runtime Error Logging Support.....	2-31
Memory Corrected Error Enabling.....	2-32
PCI-Ex (PCI-Express) Error Enable.....	2-32
Memory Correctable Error Threshold .....	2-32
Erasing Settings .....	2-32
SMBIOS Event Log Standard Settings .....	2-32
IPMI.....	2-33
IPMI Firmware Revision.....	2-33
IPMI Status .....	2-33
System Event Log.....	2-33
Enabling/Disabling Options .....	2-33
Erasing Settings .....	2-33
BMC Network Configuration.....	2-33
IPMI LAN Selection.....	2-33
IPMI Network Link Status .....	2-33
Update IPMI LAN Configuration.....	2-34
Configuration Address Source.....	2-34
Security Settings.....	2-34
Password Check.....	2-34
Administrator Password .....	2-34
Secure Boot Menu .....	2-35
Boot Settings.....	2-35
Setup Prompt Timeout.....	2-35
Boot Mode Select .....	2-35
Fixed Boot Order Priorities .....	2-35
Add New Boot Option.....	2-36

## Contents

Boot Option File Path .....	2-36
Create .....	2-36
Delete Boot Option .....	2-36
Save & Exit .....	2-36
Discard Changes and Exit .....	2-36
Save Changes and Reset .....	2-36
Save Options .....	2-36
Save Changes .....	2-36
Discard Changes .....	2-37
Restore Defaults .....	2-37
Save As User Defaults .....	2-37
Restore User Defaults .....	2-37
Boot Override .....	2-37
BIOS Error Beep Codes .....	2-37
OS Reinstallation and Recovery .....	2-38
Cleaning .....	2-39
Exterior Cleaning .....	2-39
Rack Mounting .....	2-39
Installing the Inner Slides .....	2-39
Installing the Slide Mounting Brackets in the Rack .....	2-41
Installing the Outer Slides in the Rack .....	2-42
Installing the Chassis into the Rack .....	2-43

## Chapter 3

### I/O Information

Front Panel Connectors .....	3-1
Rear Panel Connectors .....	3-1
Universal Serial Bus .....	3-2
Serial .....	3-3
VGA .....	3-4
Ethernet .....	3-5
MXI-Express Connectors .....	3-5

## Chapter 4

### Common Configuration Questions

General Questions .....	4-1
Boot Options .....	4-2
Chassis Configuration .....	4-2

## Chapter 5

### Troubleshooting

Appendix A  
Specifications

Appendix B  
Hardware Configuration

Appendix C  
NI Services

Glossary

Index

# About This Manual

---

The *RMC-8357 User Manual* contains information about installing, configuring, using, and maintaining the RMC-8357.

## Related Documentation

---

The following documents contain information that you may find helpful as you read this manual:

- *CompactPCI Specification PICMG 2.0 R 3.0*
- *PXI Hardware Specification, Revision 2.1*
- *PXI Software Specification, Revision 2.1*
- ANSI/IEEE Standard 1014-1987, *IEEE Standard for a Versatile Backplane Bus: VMEbus*
- ANSI/VITA 1-1994, *VME64*
- *NI-VISA User Manual*
- *NI-VISA Programmer Reference Manual*
- *Read Me First: Safety and Electromagnetic Compatibility*, National Instruments

---

# Getting Started

This chapter describes the key features of the RMC-8357 and lists the kit contents and optional equipment you can order from National Instruments.

## Unpacking

---

Carefully inspect the shipping container and the RMC-8357 for damage. Check for visible damage to the metal work. Check to make sure all hardware and switches are undamaged. If damage appears to have been caused during shipment, file a claim with the carrier. Retain the packing material for possible inspection and/or reshipment.

## What You Need to Get Started

---

The RMC-8357 kit contains the following items:

- RMC-8357 rack mount controller
- RMC-8357 Installation Guide*
- RMC-8357 User Manual* (available at [ni.com/support](http://ni.com/support))
- Windows recovery media (not included in diskless versions)
- 23-36 VDC 3-pin cable (ships with the DC option)

A power cable is not included with the RMC-8357 kit. Contact National Instruments if you need help finding a power cable.

**Table 1-1. AC Power Cables**

Power Cable	Reference Standards
Standard 120 V (USA)	ANSI C73.11/NEMA 5-15-P/IEC83
Switzerland 220 V	SEV
Australia 240 V	AS C112
Universal Euro 230 V	CEE (7), II, IV, VII IEC83
North America 240 V	ANSI C73.20/NEMA 5-15-P/IEC83

**Table 1-1. AC Power Cables (Continued)**

Power Cable	Reference Standards
United Kingdom 230 V	BS 1363/IEC83
Japan 100 V	ANSI C73.11/NEMA 5-15-P/IEC83

## RMC-8357 Overview

The RMC-8357 is a rugged 1U PC-based controller for remote control of PXI chassis. The controller provides leading-edge processing power with Intel Xeon E5-2620 v4 processors, high disk bandwidth with software RAID support, high I/O bandwidth with two PCI Express 3.0 x16 slots, and up to 32 GB of memory.

## Key Features

The RMC-8357 offers the performance of a high-end PC in a compact 1U rack-mountable form factor for controlling a PXI or PXI Express system using a National Instruments remote controller.

## Mainboard Features

### CPU

- Intel Xeon E5-2620 v4 Eight Core Processor, LGA 2011

### Memory

- 32 GB DDR4 RAM

### Slots

- One PCI Express 3.0 x16 slot, full height
- One PCI Express 3.0 x16 slot (requires a custom PCI Express bracket)



**Note** The x16 bottom slot requires a custom bracket and supports only half-height cards.

### Video

- PCIe video graphics card

### HDD

- One 1 TB 2.5 in. SSD
- Supports up to four 2.5 in. drives

## Blu-ray

- Slim DVD-R/W Blu-ray drive

## Onboard LAN

- Two Gigabit Ethernet ports

## Onboard I/O

- Two Serial ports
- One DisplayPort
- One DVI port
- One VGA port (disabled by default)
- Two USB 2.0 ports (rear)
- Two USB 3.0 ports (front)
- Two USB 3.0 ports (rear)

## Power Supply

- Supports redundant AC and DC power supplies

## Power Management Features

- ACPI/ACPM power management
- Wake-On-LAN (WOL) header
- Power-on mode from AC power recovery

## Front Panel LEDs

- Power indicator
- Power shuttle indicators
- LAN status indicators
- HDD indicator
- System temp (overheat) and fan (fail) warning indicator

## System Management

- Monitoring for CPU and chassis environment
- CPU thermal trip support
- +5 V standby alert LED
- Fan speed control

# RMC-8357 Description

Figures 1-1 1-2 and shows the key features of the RMC-8357 front and rear panels. For detailed information about the RMC-8357 front and rear panel, refer to Chapter 3, *I/O Information*.

**Figure 1-1.** Front View of the RMC-8357

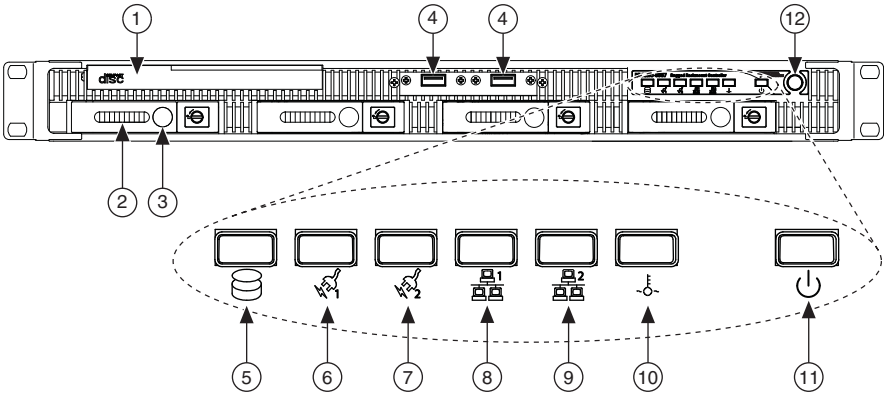

- |                                 |  |
|---------------------------------|--|
| 1 DVD-R/W Blu-ray Drive         | 7 Power Shuttle 2 Indicator              |
| 2 Hard Drives                   | 8 LAN1 Status Indicator                  |
| 3 Hard Drive Ejector Buttons    | 9 LAN2 Status Indicator                  |
| 4 USB Ports                     | 10 System Temp and Fan Warning Indicator |
| 5 Hard Drive Activity Indicator | 11 Power Indicator                       |
| 6 Power Shuttle 1 Indicator     | 12 Power Button                          |

The front panel includes the following LEDs:

- **Hard drive activity indicator**—Glow when there is hard drive activity.
- **Power shuttle indicators**—Glow when power shuttles are powered on.
- **LAN status indicators**—Flash when there is activity on LAN1 or LAN2.
- **Overheat/fan fail indicator**
  - Off—Normal
  - On—Overheat
  - Flashing—Fan failure warning
- **Power indicator**—Glow when the RMC-8357 is powered on.

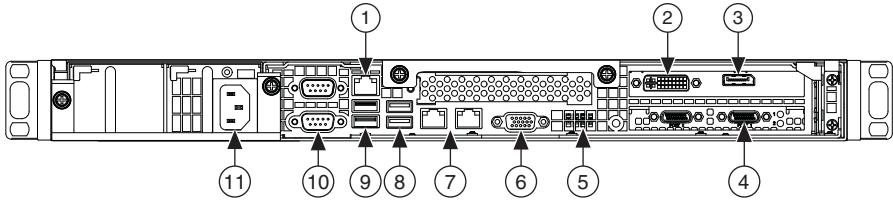

**Figure 1-2. Rear View of the RMC-8357**

- |   |                                |    |                 |
|---|--------------------------------|----|-----------------|
| 1 | IPMI Management Port           | 7  | LAN Ports       |
| 2 | DVI Port                       | 8  | USB 3.0 Ports   |
| 3 | DisplayPort                    | 9  | USB 2.0 Ports   |
| 4 | MXI x1 Ports                   | 10 | Serial Ports    |
| 5 | UID Switch                     | 11 | Power Connector |
| 6 | VGA Port (Disabled By Default) |    |                 |

---

# Installation and BIOS Setup

This chapter describes how to install, configure, and use the RMC-8357. Read this chapter before connecting the RMC-8357 to a power source.

---

## Safety Information

---



**Caution** Before undertaking any troubleshooting, maintenance, or exploratory procedure, carefully read the following caution notices.



**Caution** Product functionality can be disrupted if the knurled thumbscrews on the back of the top cover are subjected to Electrostatic Discharge (ESD). To prevent damage, you must employ industry-standard ESD prevention measures during installation, maintenance, and operation.



**Caution** Overloading the circuits may damage supply wiring. Do not exceed the ratings on the equipment nameplate when connecting equipment to the supply circuit.



**Note** Tighten the thumbscrew for the top panel cover with a tool after both initial installation and subsequent access.



**Caution** To avoid risk of explosion, do not replace the battery (JBAT1) with an incorrect battery type. Dispose of used batteries according to the battery instructions.

This equipment contains voltage hazardous to human life and safety, and is capable of inflicting personal injury.

- **Chassis Grounding**—The RMC-8357 requires a connection from the premise wire safety ground to the RMC-8357 chassis ground. The earth safety ground *must* be connected during use of this equipment to minimize shock hazards. Refer to the [Connecting Safety Ground](#) section for instructions on connecting safety ground.
- **Mechanical Loading**—To avoid a hazardous load condition, be sure the mechanical load is even when rack mounting the equipment.
- **Live Circuits**—Operating personnel and service personnel must *not* remove protective covers when operating or servicing the RMC-8357. Adjustments and service to internal components must be undertaken by qualified service technicians. During service of this product, the mains connector to the premise wiring must be disconnected. Dangerous voltages may be present under certain conditions; use extreme caution.

- **Explosive Atmosphere**—Do *not* operate the chassis in conditions where flammable gases are present. Under such conditions, this equipment is unsafe and may ignite the gases or gas fumes.
- **Parts Replacement**—Service this equipment only with parts that are exact replacements, both electrically and mechanically. Contact National Instruments for replacement part information. Installation of parts with those that are not direct replacements may cause harm to personnel operating the chassis. Furthermore, damage or fire may occur if replacement parts are unsuitable.
- **Modification**—Do *not* modify any part of the RMC-8357 from its original condition. Unsuitable modifications may result in safety hazards.

## Chassis Cooling Considerations

---

The RMC-8357 is designed to operate on a bench or in an instrument rack. Determine how you want to use the RMC-8357 and follow the appropriate installation instructions.



**Caution** If installed in a closed or multiunit rack assembly, the rack environment operating ambient temperature may be greater than room ambient temperature. Therefore, install the equipment in an environment compatible with the maximum ambient operating temperature (T<sub>ma</sub>) specified in Appendix A, *Specifications*.

## Providing Adequate Clearance

Apertures in the front and rear of the chassis facilitate power supply and motherboard cooling. Air enters through the front of the chassis and exits through the fans on the rear of the chassis. Place the RMC-8357 on a bench top or in an instrument rack so that the fans (air outlets) and the air inlet apertures in the front and rear of the chassis have adequate ventilation. Keep other equipment a minimum of 76.2 mm (3 in.) away from the air outlets on the rear of the chassis.

## Installation

---

Follow these steps to connect devices to the RMC-8357:

1. Connect a keyboard and mouse to the appropriate connectors on the RMC-8357 rear panel.
2. Connect the DVI or DisplayPort monitor video cable to the DVI or DisplayPort connector on the rear panel.
3. Connect the USB and serial devices as necessary to the RMC-8357 front and rear panel ports.



**Caution** To minimize shock hazard, make sure the electrical power outlet you use to power the RMC-8357 has an appropriate earth safety ground. Refer to the *Connecting Safety Ground* section for more information.



**Caution** Use the DC power cable provided with DC power supplies for VDC input.

4. Connect the AC power cable to the AC inlet on the rear panel and to an AC power outlet. For more information, refer to the [Connecting to Power Source](#) section.
5. For the DC option, connect the DC positronic connector to the DC inlet on the rear panel and wire to a DC power source.
6. Power on the RMC-8357.
7. Verify that the RMC-8357 boots. If it does not boot, refer to the [What if the RMC-8357 does not boot?](#) section of Chapter 5, [Troubleshooting](#).

## Connecting Safety Ground

---

The RMC-8357 is designed with a three-position IEC C14 style plug that connects the ground line to the chassis ground. To minimize shock hazard, make sure the electrical power outlet you use to power the chassis has an appropriate earth safety ground.



**Note** The RMC-8357 also includes a grounding screw (8-32 thread size nut) on the back of the chassis. (The nut is not supplied with the RMC-8357.)

## Connecting to Power Source

---

Attach input power through the rear AC/DC inlet using the appropriate AC/DC power cable supplied.



**Caution** Overloading the circuits may damage supply wiring. Do not exceed the ratings on the equipment nameplate when connecting equipment to the supply circuit.



**Caution** To completely remove power, you *must* disconnect the AC/DC power cable.



**Caution** For a DC power supply, provide a 30 A or higher overcurrent protection device external to the equipment.

The power switch allows you to power on the chassis or place it in standby mode. Push the power switch to the On position (if not already on). Observe that all fans become operational and the power indicator is lit.

## BIOS Setup

---

This section describes the AMI BIOS™ Setup utility for the RMC-8357 motherboard. The ROM BIOS is stored in a Flash EEPROM and can be easily updated.



**Note** Due to periodic changes to the BIOS, some settings may have been added or deleted and might not yet be recorded in this manual. Refer to [ni.com/downloads](http://ni.com/downloads) for any changes to BIOS that may not be reflected in this manual.

# Starting the BIOS Setup Utility

To enter the BIOS Setup Utility, press the <Delete> key while the system is booting-up.



**Note** In most cases, the <Delete> key is used to invoke the AMI BIOS setup screen. There are a few cases when other keys are used, such as <F1>, <F2>, etc...

Each main BIOS menu option is described in this manual. The AMI BIOS setup menu screen has two main frames. The left frame displays all the options that can be configured. Grayed-out options cannot be configured. Options in blue can be configured by the user. The right frame displays the key legend. Above the key legend is an area reserved for a text message. When an option is selected in the left frame, it is highlighted in white. Often a text message will accompany it. Highlighting a submenu and pressing the <Enter> key will open the list of settings within that submenu.



**Note** The AMI BIOS has default text messages built in.

The BIOS setup utility uses a key-based navigation system called hot keys. Most of these hot keys (<F1>, <F10>, <Enter>, <ESC>, <Arrow> keys, etc.) can be used at any time during the setup navigation process.



**Note** Options in **Bold** are default settings.

## How to Change the Configuration Data

The configuration data that determines the system parameters may be changed by entering the AMI BIOS setup utility. This setup utility can be accessed by pressing <Del> at the appropriate time during system boot.

## How to Start the Setup Utility

Normally, the only visible Power-On Self-Test (POST) routine is the memory test. As the memory is being tested, press the <Delete> key to enter the main menu of the AMI BIOS setup utility. From the main menu, you can access the other setup screens. An AMI BIOS identification string is displayed at the left bottom corner of the screen, below the copyright message.



**Caution** Do not upgrade the BIOS unless your system has a BIOS-related issue. Flashing the wrong BIOS can cause irreparable damage to the system. In no event shall National Instruments be liable for direct, indirect, special, incidental, or consequential damages arising from a BIOS update.

# Main Setup

---

When you first enter the AMI BIOS setup utility, you will enter the Main setup screen. You can always return to the Main setup screen by selecting the Main tab on the top of the screen. The following Main menu items will be displayed:

## System Date/System Time

Use this option to change the system date and time. Highlight *System Date* or *System Time* using the arrow keys. Enter new values using the keyboard. Press the <Tab> key or the arrow keys to move between fields. The date must be entered in Day MM/DD/YYYY format. The time is entered in HH:MM:SS format.



**Note** The time is in the 24-hour format. For example, 5:30 P.M. appears as 17:30:00. The date's default value is 01/01/2015 after RTC reset.

## BIOS Version

This item displays the version of the BIOS ROM used in the system.

## Build Date

This item displays the date when the version of the BIOS ROM used in the system was built.

## Memory Information

### Total Memory

This item displays the total size of memory available in the system.

### Memory Speed

This item displays the default speed of the memory modules installed in the system.

## Advanced Setup Configurations

---

Use the arrow keys to select Advanced Setup and press <Enter> to access the submenu items.



**Caution** Take caution when changing the Advanced settings. An incorrect value, a very high DRAM frequency, or an incorrect BIOS timing setting may cause the system to malfunction. When this occurs, restore the setting to the default setting.

## Boot Feature

### Quiet Boot

Use this feature to select the screen display between the POST messages or the OEM logo at bootup. Select **Disabled** to display the POST messages. Select **Enabled** to display the OEM logo instead of the normal POST messages. The options are **Enabled** and **Disabled**.

### AddOn ROM Display Mode

Use this item to set the display mode for the Option ROM. Select **Keep Current** to display the current AddOn ROM display setting. Select **Force BIOS** to use the Option ROM display set by the system BIOS. The options are **Force BIOS** and **Keep Current**.

### Bootup NumLock State

Use this feature to set the Power-on state for the <Numlock> key. The options are **Off** and **On**.

### Wait For F1 If Error

Use this feature to force the system to wait until the <F1> key is pressed if an error occurs. The options are **Disabled** and **Enabled**.

### INT19 (Interrupt 19) Trap Response

Interrupt 19 is the software interrupt that handles the boot disk function. When this item is set to Immediate, the ROM BIOS of the host adapters will capture Interrupt 19 at bootup immediately and allow the drives that are attached to these host adapters to function as bootable disks. If this item is set to Postponed, the ROM BIOS of the host adapters will not capture Interrupt 19 immediately and allow the drives attached to these adapters to function as bootable devices at bootup. The options are **Immediate** and **Postponed**.

### Re-try Boot

When EFI Boot is selected, the system BIOS will automatically reboot the system from an EFI boot device after its initial boot failure. Select **Legacy Boot**, to allow the BIOS to automatically reboot the system from a Legacy boot device after its initial boot failure. The options are **Disabled**, **Legacy Boot**, and **EFI Boot**.

## Power Configuration

### DeepSx Power Policies

Use this item to configure the Advanced Configuration and Power Interface (ACPI) settings for the system. Enable S3 to use Standby Mode (Suspend-to-RAM) and maintain power supply to the system RAM when the system is in the sleep mode. Enable S4 to use Hibernation mode (Suspend to Disk) so that all data stored in of the main memory can be saved in a non-volatile memory area such as in a hard drive and then power down the system. Enable S5 to power off the whole system except the power supply unit (PSU) and keep the power button alive so that

the user can wake-up the system by using an USB keyboard or mouse. The options are **Disabled**, **Enabled in S5**, **Enabled in S4-S5**, and **Enabled in S3-S4-S5**.

## Watch Dog Function

Select **Enabled** to allow the Watch Dog Timer to reboot the system when it is inactive for more than 5 minutes. The options are **Enabled** and **Disabled**.

## Power Button Function

This feature controls how the system shuts down when the power button is pressed. Select **4\_Seconds\_Override** for the user to power off the system after pressing and holding the power button for 4 seconds or longer. Select **Instant Off** to instantly power off the system as soon as the user presses the power button. The options are **4 Seconds Override** and **Instant Off**.

## Restore on AC Power Loss

Use this feature to set the power state after a power outage. Select **Stay-Off** for the system power to remain off after a power loss. Select **Power-On** for the system power to be turned on after a power loss. Select **Last State** to allow the system to resume its last power state before a power loss. The options are **Power-On**, **Stay-Off** and **Last State**.

## Chipset Configuration



**Caution** Setting the wrong values in the following sections may cause the system to malfunction.

## CPU Configuration

The following CPU information will display:

- Processor Socket
- Processor ID
- Processor Frequency
- Max (Maximum) CPU Speed
- Min (Minimum) CPU Speed
- Processor Max Ratio
- Processor Min Ratio
- Microcode Revision
- L1 Cache RAM
- L2 Cache RAM
- L3 Cache RAM
- CPU1 Version



## Clock Spread Spectrum

Select **Enable for Clock Spectrum** support, which will allow the BIOS to monitor and attempt to reduce the level of Electromagnetic Interference caused by the components whenever needed. Select **Disabled** to enhance system stability. The options are **Disabled** and **Enabled**.

## Hyper-Threading

Select **Enable** to use Intel Hyper-Threading Technology to enhance CPU performance. The options are **Enable** and **Disable**.

## Performance/Watt

Select **Power Optimized** to use Intel Turbo Boost Technology to maximize system performance (with maximum cooling) when performance state P0 lasts more than two seconds. If Traditional is selected, Intel Turbo Boost Technology will be activated even when performance state P0 lasts less than two seconds. The options are **Traditional** and **Power Optimized**.

## Execute Disable Bit

Set to **Enabled** for Execute Disable Bit support which will allow the processor to designate areas in the system memory where an application code can execute and where it cannot, thus preventing a worm or a virus from loading illegal codes to overwhelm the processor or damaging the system during a virus attack. The options are **Enable** and **Disable**. (Refer to Intel and Microsoft websites for more information.)



**Note** Available when supported by the CPU.

## PPIN Control

Select **Unlock/Enable** to use the Protected-Processor Inventory Number (PPIN) in the system. The options are **Unlock/Enable** and **Unlock/Disable**.

## Hardware Prefetcher

If this item is set to **Enable**, the hardware prefetcher will prefetch streams of data and instructions from the main memory to the Level 2 (L2) cache to improve CPU performance. The options are **Disable** and **Enable**.



**Note** Available when supported by the CPU.

## Adjacent Cache Line Prefetch

Select **Enable** for the CPU to prefetch both cache lines for 128 bytes as comprised. Select **Disable** for the CPU to prefetch both cache lines for 64 bytes. The options are **Disable** and **Enable**.



**Note** Available when supported by the CPU.



**Note** If there is any change to this setting, you will need to power off and reboot the system for the change to take effect. Please refer to Intel's web site for detailed information.

## DCU Streamer Prefetcher

If this item is set to **Enable**, the DCU (Data Cache Unit) streamer prefetcher will prefetch data streams from the cache memory to the DCU (Data Cache Unit) to speed up data accessing and processing for CPU performance enhancement. The options are **Disable** and **Enable**.



**Note** Available when supported by the CPU.

## DCU IP Prefetcher

If this item is set to **Enable**, the IP prefetcher in the DCU (Data Cache Unit) will prefetch IP addresses to improve network connectivity and system performance. The options are **Enable** and **Disable**.

## DCU (Data Cache Unit) Mode

Use this item to set the DCU data-prefetching mode. The options are **32KB 8Way Without ECC** and **16KB 4Way With ECC**.

## Direct Cache Access (DCA)

Select **Enable** to use Intel DCA (Direct Cache Access) Technology to maximize efficiency in memory data transferring and accessing. The options are **Auto**, **Enable** and **Disable**.

## DCA Prefetch Delay

A DCA prefetcher is used with a TOE (TCP/IP Offload Engine) adapter to prefetch data to shorten execution cycles and to maximize data processing efficiency. Prefetching data too frequently can saturate the cache directory and delay necessary cache access. This feature reduces or increases the frequency of system data prefetching activities. The options are **Disable**, **[8]**, **[16]**, **[32]**, **[40]**, **[48]**, **[56]**, **[64]**, **[72]**, **[80]**, **[88]**, **[96]**, **[104]**, and **[112]**.

## X2APIC (Extended Advanced Programmable Interrupt Controller)

Based on the Intel Hyper-Threading technology, each logical processor (thread) is assigned 256 APIC IDs (APIDs) in 8-bit bandwidth. When this item is set to **Enable**, the APIC ID will be expanded from 8 bits to 16 bits to provide 512 APIDs to each thread to enhance CPU performance. The options are **Disable** and **Enable**.

## AES-NI

Select **Enable** to use the Intel Advanced Encryption Standard (AES) New Instructions (NI) to ensure data security. The options are **Enable** and **Disable**.

## Intel Virtualization Technology

Select **Enable** to use Intel Virtualization Technology so that I/O device assignments will be reported directly to the VMM (Virtual Memory Management) through the DMAR ACPI Tables. This feature offers fully-protected I/O resource-sharing across the Intel platforms, providing the user with greater reliability, security and availability in networking and data-sharing. The settings are **Enable** and **Disable**.

## Advanced Power Management Configuration

### Power Technology

Select **Energy Efficient** to support power-saving mode. Select **Custom** to customize system power settings. Select **Disabled** to disable power-saving settings. The options are **Disable**, **Energy Efficient**, and **Custom**.

### Config TDP

Select **Enable** to allow the user to configure the Thermal Design Power (TDP) settings for the system. The TDP refers to the maximum amount of power allowed for running “real applications” without triggering an overheating event. The options are **Disable** and **Enable**.

## CPU P State Control

### EIST (P-State)

EIST (Enhanced Intel SpeedStep Technology) allows the system to automatically adjust processor voltage and core frequency in an effort to reduce power consumption and heat dissipation. Please refer to Intel’s website for detailed information. The options are **Disable** and **Enable**.

### Turbo Mode

Select **Enable** for processor cores to run faster than the frequency specified by the manufacturer. The options are **Disable** and **Enable**.

### P-state Coordination

Use this item to configure the processor's P-State coordination settings. During a P-State, the voltage and frequency of the processor will be reduced when it is in operation. This makes the processor more energy efficient, resulting in further energy gains. The options are **HW\_ALL**, **SW\_ALL** and **SW-ANY**.

## CPU C State Control

### Package C State limit

Use this item to set the limit on the C-State package register. The options are **C0/1 state**, **C2 state**, **C6 (non-Retention) state**, and **C6 (Retention) state**.

## CPU C3 Report

Select **Enable** to allow the BIOS to report the CPU C3 State (ACPI C2) to the operating system. During the CPU C3 State, the CPU clock generator is turned off. The options are **Enable** and **Disable**.

## CPU C6 Report

Select **Enable** to allow the BIOS to report the CPU C6 state (ACPI C3) to the operating system. During the CPU C6 state, power to all caches is turned off. The options are **Enable** and **Disable**.



**Note** Available when Power Technology is set to Custom.

## Enhanced Halt State (C1E)

Select **Enabled** to enable "Enhanced Halt State" support, which will significantly reduce the CPU's power consumption by minimizing CPU's clock cycles and voltage use during a "Halt State." The options are **Disable** and **Enable**.

## CPU T State Control

### ACPI (Advanced Configuration Power Interface) T-States

If this item is set to **Enable**, CPU throttling will be supported by the operating system to reduce power consumption. The options are **Enable** and **Disable**.

## Socket RAPL (Running Average Power Limit) Configuration

### FAST-RAPL-NSTRIKE-PL2-DUTY-CYCLE

This feature displays the value of the item above within the range between 25 (10%) and 64 (25%).

### Turbo Power Limit Lock

Select **Enable** to set the power use limit for the machine when it is running in the turbo mode. The options are **Enable** and **Disable**.

### Long Power Limit Override

Select **Enable** to support long-term power limit override. If this feature is disabled, BIOS will set the default value. The options are **Enable** and **Disable**.

### Long Duration Power Limit

This item displays the power limit set by the user during which long duration power is maintained. The default setting is **0**.

## Package Clamping Limit1

Use this item to set the limit on power performance states for the run-time processor, with P0 being the state with the highest frequency (clock speed) and power (consumption), and P1, a step lower in performance than P0, with its frequency and voltage scaled back a notch. The options are **Between P1/P0** and **Below P1**.

## Short Duration Power Limit Enable

Select **Enable** to support Short Duration Power Limit (Power Limit 2). The options are **Enable** and **Disable**.

## Short Duration Power Limit

This item displays the time period during which short duration power is maintained. The default setting is **0**.

## Package Clamping Limit2

Use this item to set the limit on power performance states for the processor operating in turbo mode, with P0 being the state with the highest frequency (clock speed) and power (consumption), and P1, a step lower in performance than P0, with its frequency and voltage scaled back a notch. The options are **Between P1/P0** and **Below P1**.

# Chipset Configuration

---

## North Bridge

This feature allows the user to configure the settings for the Intel North Bridge.

## I/O Configuration

### EV DFX (Device Function On-Hide) Feature

When this feature is set to **Enable**, the EV\_DFX Lock Bits that are located on a processor will always remain clear during electric tuning. The options are **Disable** and **Enable**.

## I/O1 Configuration/I/O2 Configuration

### IOU2 (I/O PCIe Port 1)

This item configures the PCI-E port Bifurcation setting for a PCI-E port specified by the user. The options are **x4x4**, **X8**, and **Auto**.

### PORT 1A Link Speed

This item configures the link speed of a PCI-E port specified by the user. The options are **Gen 1 (Generation 1) (2.5 GT/s)**, **Gen 2 (Generation 2) (5 GT/s)** and **Gen 3 (Generation 3) (8 GT/s)**.

## IOU0 (IIO PCIe Port 2)

This item configures the PCI-E port Bifurcation setting for a PCI-E port specified by the user. The options are **x4x4x4x4**, **x4x4x8**, **x8x4x4**, **x8x8**, **x16**, and **Auto**.

## PORT 2A Link Speed

Use this item to configure the link speed of a PCI-E port specified by the user. The options are **Gen 1 (Generation 1) (2.5 GT/s)**, **Gen 2 (Generation 2) (5 GT/s)** and **Gen 3 (Generation 3) (8 GT/s)**.

## IOU1 (IIO PCIE Port 3)

Use this item to configure the PCI-E port Bifurcation setting for a PCI-E port specified by the user. The options are **x4x4x4x4**, **x4x4x8**, **x8x4x4**, **x8x8**, **x16**, and **Auto**.

## PORT 3A Link Speed

Use this item to configure the link speed of a PCI-E port specified by the user. The options are **Gen 1 (Generation 1) (2.5 GT/s)**, **Gen 2 (Generation 2) (5 GT/s)** and **Gen 3 (Generation 3) (8 GT/s)**.

## PCI-E Completion Timeout

Select **Enable** for PCI-E Completion Timeout support for electric tuning. The options are **Enable** and **Disable**.

## PCI-E Completion Timeout Value

Use this item to set the PCI-E Completion Time-out value for electric tuning. Enter a value between 260 ms to 900 ms.

# IOAT Configuration

## Enable I/OAT

Select **Enable** to enable Intel I/OAT (I/O Acceleration Technology), which significantly reduces CPU overhead by leveraging CPU architectural improvements and freeing the system resource for other tasks. The options are **Enable** and **Disable**.

## No Snoop

Select **Enable** to support no-snoop mode for each CB device. The options are **Disable** and **Enable**.

## Relaxed Ordering

Select **Enable** to enable Relaxed Ordering support which will allow certain transactions to violate the strict-ordering rules of PCI and to be completed prior to other transactions that have already been enqueued. The options are **Disable** and **Enable**.

## Intel VT for Directed I/O (VT-d)

Select **Enable** to use Intel Virtualization Technology support for Direct I/O VT-d support by reporting the I/O device assignments to the VMM (Virtual Machine Monitor) through the DMAR ACPI Tables. This feature offers fully-protected I/O resource sharing across Intel platforms, providing greater reliability, security and availability in networking and data-sharing. The options are **Enable** and **Disable**.

## Interrupt Remapping

Select **Enable** for Interrupt Remapping support to enhance system performance. The options are **Enable** and **Disable**.

## Coherency Support (Non-Iscoch)

Select **Enable** for the Non-Iscoch VT-d engine to pass through DMA (Direct Memory Access) to enhance system performance. The options are **Enable** and **Disable**.

## Coherency Support (Iscoch)

Select **Enable** for the Iscoch VT-d engine to pass through ATS to enhance system performance. The options are **Enable** and **Disable**.

## QPI (Quick Path Interconnect) Configuration

### QPI Status

The following information will display:

- Number of CPU
- Number of IIO
- Current QPI Link Speed
- Current QPI Link Frequency
- QPI Global MMIO Low Base/Limit
- QPI Global MMIO High Base/Limit
- QPI PCIe Configuration Base/Size

### Link Speed Mode

Use this item to select the data transfer speed for QPI Link connections. The options are **Fast** and **Slow**.

### Link Frequency Select

Use this item to select the desired frequency for QPI Link connections. The options are **6.4 GB/s**, **8.0 GB/s**, **9.6 GB/s**, **Auto**, and **Auto Limited**.

## Link L0p Enable

Select **Enable** for Link L0p support. The options are **Enable**, **Auto**, and **Disable**.

## Link L1 Enable

Select **Enable** for Link L1 support. The options are **Enable**, **Auto**, and **Disable**.

## Isoc Mode

Select **Enabled** for Isochronous support to meet QoS (Quality of Service) requirements. This feature is especially important for Virtualization Technology. The options are **Enable** and **Disable**.

## Memory Configuration

### Enforce POR

Select **Enable** to enforce POR restrictions for DDR4 frequency and voltage programming. The options are **Enabled** and **Disabled**.

### Memory Frequency

Use this feature to set the maximum memory frequency for onboard memory modules. The options are **Auto**, **1333**, **1400**, **1600**, **1800**, **1867**, **2000**, **2133**, **2200**, **2400**, **2600**, **2667**, and **Reserved** (Do not select Reserved).

### ECC Support

Select **Enable** to enable Error Checking & Correction (ECC) support for onboard memory modules. The options are **Auto**, **Enable** and **Disable**.

### Data Scrambling

Select **Enabled** to enable data scrambling to enhance system performance and data integrity. The options are **Auto**, **Disabled** and **Enabled**.

### Enable ADR

Select **Enabled** for ADR (Automatic Diagnostic Repository) support to enhance memory performance. The options are **Enabled** and **Disabled**.

### DRAM RAPL (Running Average Power Limit) Baseline

Use this feature to set the run-time power-limit baseline for DRAM modules. The options are **Disable**, **DRAM RAPL Mode 0**, and **DRAM RAPL Mode 1**.



## Set Throttling Mode

Throttling improves reliability and reduces power consumption in the processor via automatic voltage control during processor idle states. The options are **Disabled** and **CLTT** (Closed Loop Thermal Throttling).

## Socket Interleave Below 4GB

Select **Enabled** for the memory above the 4G Address space to be split between two sockets. The options are **Enable** and **Disable**.

## Channel Interleaving

Use this item to set DIMM channel interleaving mood. The options are **Auto**, **1 Way Interleave**, **2 Way Interleave**, **3, Way Interleave**, and **4 Way Interleave**.

## Rank Interleaving

Use this item to select a rank memory interleaving method. The options are **Auto**, **1 Way**, **2 Way**, **4 Way**, and **8 Way**.

## A7 Mode

Select **Enabled** to support A7 (Addressing) Mode to improve memory performance. The options are **Enable** and **Disable**.

## DIMM Information

This item displays the status of a DIMM module specified.

- DIMMA1
- DIMMA2
- DIMMB1
- DIMMB2
- DIMMC1
- DIMMC2
- DIMMD1
- DIMMD2

## Memory RAS (Reliability\_Availability\_Serviceability) Configuration

Use this submenu to configure the following Memory RAS settings.

### RAS Mode

Select **Enable** to enable RAS support to enhance reliability, availability and serviceability of onboard memory modules. The options are **Enable** and **Disable**.

## Lockstep x4 DIMMs

Select **Enable** to enable Lockstep Technology support for x4 DIMM modules. The options are **Auto**, **Disabled**, and **Enabled**.

## Memory Rank Sparing

This item indicates if memory rank sparing is supported by the motherboard. Memory rank sparing enhances system memory performance. The options are **Enabled** and **Disabled**.

## Patrol Scrub

Patrol Scrubbing is a process that allows the CPU to correct correctable memory errors detected in a memory module and send the correction to the requestor (the original source). When this item is set to **Enable**, the IO hub will read and write back one cache line every 16 K cycles if there is no delay caused by internal processing. By using this method, roughly 64 GB of memory behind the IO hub will be scrubbed every day. The options are **Enable** and **Disable**.

## Patrol Scrub Interval

Use this item to specify the number of hours (between 0 to 24) required for the system to complete a full patrol scrubbing. Enter 0 for patrol scrubbing to be performed automatically. The default setting is **24**.

## Demand Scrub

Demand Scrubbing is a process that allows the CPU to correct correctable memory errors found in a memory module. When the CPU or I/O issues a demand-read command, and the read data from memory turns out to be a correctable error, the error is corrected and sent to the requestor (the original source). Memory is corrected as well. Select **Enable** to use Demand Scrubbing for ECC memory correction. The options are **Enable** and **Disable**.

## Device Tagging

Select **Enable** to support device tagging. The options are **Disable** and **Enable**.

## South Bridge

The following South Bridge information will display:

- USB Configuration
- USB Module Version
- USB Devices

## Legacy USB Support

Select **Enabled** to support onboard legacy USB devices. Select **Auto** to disable legacy support if there are no legacy USB devices present. Select **Disable** to have all USB devices available for EFI applications only. The options are **Enabled**, **Disabled** and **Auto**.

## XHCI Hand-Off

This is a work-around solution for operating systems that do not support XHCI (Extensible Host Controller Interface) hand-off. The XHCI ownership change should be claimed by the XHCI driver. The settings are **Enabled** and **Disabled**.

## EHCI Hand-Off

This item is for operating systems that do not support Enhanced Host Controller Interface (EHCI) hand-off. When this item is enabled, EHCI ownership change will be claimed by the EHCI driver. The settings are **Enabled** and **Disabled**.

## USB Mass Storage Driver Support

Select **Enabled** for USB mass storage device support. The options are **Disabled** and **Enabled**.

## Port 60/64 Emulation

Select **Enabled** for I/O port 60h/64h emulation support, which in turn, will provide complete legacy USB keyboard support for the operating systems that do not support legacy USB devices. The options are **Disabled** and **Enabled**.

## USB 3.0 Support

Select **Enabled** for USB 3.0 support. The options are **Disabled**, **Enabled** and **Auto**.

## EHCI1

Select **Enabled** to enable EHCI (Enhanced Host Controller Interface) support on USB 2.0 connector #1 (-at least one USB 2.0 connector should be enabled for EHCI support.) The options are **Disabled** and **Enabled**.

## EHCI2

Select **Enabled** to enable EHCI (Enhanced Host Controller Interface) support on USB 2.0 connector #2 (-at least one USB 2.0 connector should be enabled for EHCI support.) The options are **Disabled** and **Enabled**.

## XHCI Pre-Boot Drive

Select **Enabled** to enable XHCI (Extensible Host Controller Interface) support on a pre-boot drive specified by the user. The options are **Enabled** and **Disabled**.

## XHCI Idle L1

Select **Enabled** for XHCI (Extensible Host Controller Interface) Idle Level 1 support on a USB 3.0 connector specified by the user. The options are **Enabled** and **Disabled**.

## PCH DMI ASPM

Select **Enabled** to enable ASPM (Active State Power Management) support for a PCH DMI drive. The options are **Disabled** and **Enabled**.

## SATA Configuration

When this submenu is selected, the AMI BIOS automatically detects the presence of the SATA devices that are supported by the Intel PCH chip and displays the following items:

### SATA Controller

This item enables or disables the onboard SATA controller supported by the Intel PCH chip. The options are **Enabled** and **Disabled**.

### Configure SATA as

Select **IDE** to configure a SATA drive specified by the user as an IDE drive. Select **AHCI** to configure a SATA drive specified by the user as an AHCI drive. Select **RAID** to configure a SATA drive specified by the user as a RAID drive. The options are **IDE**, **AHCI**, and **RAID**.

If the item above "Configure SATA as" is set to AHCI, the following items will display:

### Support Aggressive Link Power Management

When this item is set to **Enabled**, the SATA AHCI controller manages the power usage of the SATA link. The controller will put the link in a low power mode during extended periods of I/O inactivity, and will return the link to an active state when I/O activity resumes. The options are **Enabled** and **Disabled**.

### SATA Port 0 ~ Port 5

This item displays the information detected on the installed SATA drive on the particular SATA port.

- Model number of drive and capacity
- Software Preserve Support

### Port 0 ~ Port 5

Select **Enabled** to enable a SATA port specified by the user. The options are **Disabled** and **Enabled**.

### Port 0 ~ Port 5 Hot Plug

This feature designates the port specified for hot plugging. Set this item to **Enabled** for hot-plugging support, which will allow the user to replace a SATA disk drive without shutting down the system. The options are **Enabled** and **Disabled**.

### Port 0 ~ Port 5 Spin Up Device

On an edge detect from 0 to 1, set this item to allow the PCH to initialize the device. The options are **Enabled** and **Disabled**.

### Port 0 ~ Port 5 SATA Device Type

Use this item to specify if the SATA port specified by the user should be connected to a Solid State drive or a Hard Disk Drive. The options are **Hard Disk Drive** and **Solid State Drive**.

If the item above "Configure SATA as" is set to IDE, the following items will display:

### Serial ATA Port 0 ~ Port 5

This item indicates that a SATA port specified by the user is not installed or not present.

### Port 0 ~ Port 5 SATA Device Type

Use this item to specify if the SATA port specified by the user should be connected to a Solid State drive or a Hard Disk Drive. The options are **Hard Disk Drive** and **Solid State Drive**.



**Note** Available when a SATA port is detected.

\*If the item above "Configure SATA as" is set to RAID, the following items will display:

### Support Aggressive Link Power Management

When this item is set to **Enabled**, the SATA AHCI controller manages the power usage of the SATA link. The controller will put the link in a low power mode during extended periods of I/O inactivity, and will return the link to an active state when I/O activity resumes. The options are **Enabled** and **Disabled**.

### SATA RAID Option ROM/UEFI Driver

Select **EFI** to load the EFI driver for system boot. Select **Legacy** to load a legacy driver for system boot. The options are **Disabled**, **EFI**, and **Legacy**.

### Serial ATA Port 0 ~ Port 5

This item displays the information detected on the installed SATA drives on the particular SATA port.

- Model number of drive and capacity
- Software Preserve Support

### Port 0 ~ Port 5

Select **Enabled** to enable a SATA port specified by the user. The options are **Disabled** and **Enabled**.

### Port 0 ~ Port 5 Hot Plug

This feature designates this port for hot plugging. Set this item to **Enabled** for hot-plugging support, which will allow the user to replace a SATA drive without shutting down the system. The options are **Enabled** and **Disabled**.

### Port 0 ~ Port 5 Spin Up Device

On an edge detect from 0 to 1, set this item to allow the PCH to start a COMRE- SET initialization to the device. The options are **Enabled** and **Disabled**.

## Port 0 ~ Port 5 SATA Device Type

Use this item to specify if the SATA port specified by the user should be connected to a Solid State drive or a Hard Disk Drive. The options are **Hard Disk Drive** and **Solid State Drive**.

## sSATA Configuration

When this submenu is selected, the AMI BIOS automatically detects the presence of the SATA devices that are supported by the SCU controller and displays the following items:

### sSATA Controller

This item enables or disables the onboard SATA controller supported by the Intel SCU chip. The options are **Enabled** and **Disabled**.

### Configure sSATA as

Select **IDE** to configure an sSATA drive specified by the user as an IDE drive. Select **AHCI** to configure an sSATA drive specified by the user as an AHCI drive. Select **RAID** to configure an sSATA drive specified by the user as a RAID drive. The options are **IDE**, **AHCI**, and **RAID**.

If the item above "Configure sSATA as" is set to AHCI, the following items will display:

### Support Aggressive Link Power Management

When this item is set to **Enabled**, the sSATA AHCI controller manages the power usage of the sSATA link. The controller will put the link in a low power mode during extended periods of I/O inactivity, and will return the link to an active state when I/O activity resumes. The options are **Enabled** and **Disabled**.

### sSATA Port 0 ~ Port 3

This item displays the information detected on the installed sSATA drives on the particular sSATA port.

- Model number of drive and capacity
- Software Preserve Support

### sSATA Port 0 ~ Port 3

Select **Enabled** to enable an sSATA port specified by the user. The options are **Disabled** and **Enabled**.

### sSATA Port 0 ~ Port 3 Hot Plug

This feature designates the sSATA port specified for hot plugging. Set this item to **Enabled** for hot-plugging support, which will allow the user to replace an sSATA disk drive without shutting down the system. The options are **Enabled** and **Disabled**.

### sSATA Port 0 ~ Port 3 Spin Up Device

On an edge detect from 0 to 1, set this item to allow the PCH to start a COMRE- SET initialization to the device. The options are **Enabled** and **Disabled**.

## Port 0 ~ Port 3 sSATA Device Type

Use this item to specify if the sSATA port specified by the user should be connected to a Solid State drive or a Hard Disk Drive. The options are **Hard Disk Drive** and **Solid State Drive**.

If the item above "Configure sSATA as" is set to IDE, the following items will display:

### sSATA Port 0 ~ Port 3

This item indicates that an sSATA port specified by the user is not installed or not detected.

## Port 0 ~ Port 3 sSATA Device Type

Use this item to specify if the sSATA port specified by the user should be connected to a Solid State drive or a Hard Disk Drive. The options are **Hard Disk Drive** and **Solid State Drive**.



**Note** Available when supported a SATA port is detected.

If the item above "Configure sSATA as" is set to RAID, the following items will display:

## Support Aggressive Link Power Management

When this item is set to **Enabled**, the SATA AHCI controller manages the power usage of the SATA link. The controller will put the link in a low power mode during extended periods of I/O inactivity, and will return the link to an active state when I/O activity resumes. The options are **Enabled** and **Disabled**.

## sSATA RAID Option ROM/UEFI Driver

Select **EFI** to load the EFI driver for system boot. Select **Legacy** to load a legacy driver for system boot. The options are **Disabled**, **EFI**, and **Legacy**.

### sSATA Port 0 ~ Port 3

This item displays the information detected on the installed sSATA drives on the particular sSATA port.

- Model number of drive and capacity
- Software Preserve Support

### sSATA Port 0 ~ Port 3

Select **Enabled** to enable an sSATA port specified by the user. The options are **Disabled** and **Enabled**.

## sSATA Port 0 ~ Port 3 Hot Plug

This feature designates this port for hot plugging. Set this item to **Enabled** for hot-plugging support, which will allow the user to replace an sSATA drive without shutting down the system. The options are **Enabled** and **Disabled**.

## sSATA Port 0 ~ Port 3 Spin Up Device

On an edge detect from 0 to 1, set this item to allow the PCH to start a COMRE- SET initialization to the device. The options are **Enabled** and **Disabled**.

## Port 0 ~ Port 3 sSATA Device Type

Use this item to specify if the sSATA port specified by the user should be connected to a Solid State drive or a Hard Disk Drive. The options are **Hard Disk Drive** and **Solid State Drive**.

# Server ME (Management Engine) Configuration

This feature displays the following system ME configuration settings.

- General ME Configuration
- Operational Firmware Version
- Recovery Firmware Version
- ME Firmware Features
- ME Firmware Status #1
- ME Firmware Status #2
- Current State
- Error Code

## PCIe/PCI/PnP Configuration

The following PCI information will be displayed:

- PCI Bus Driver Version
- PCI Latency Timer

## PCI AER (Advanced Error-Reporting) Support

Use this item to configure the PCI-X latency timer for a device installed on a PCI-X bus. Select **64** to set the PCI-X latency timer to 64 PCI clock cycles. The options are **32, 64, 96, 128, 160, 192, 224** and **248** (PCI Bus Clocks).

## VGA Palette Snoop

Select **Enabled** to support VGA palette register snooping which will allow a PCI card that does not contain its own VGA color palette to examine a video card palette and mimic it for proper color display. The options are **Disabled** and **Enabled**.

## PERR# Generation Support

Select **Enabled** to allow a PCI device to generate a PERR (PCI/PCI-E Parity Error) number for a PCI bus error event. The options are **Enabled** and **Disabled**.



## SERR# Generation Support

Select **Enabled** to allow a PCI device to generate an SERR (System Error) number for a PCI bus error event. The options are **Enabled** and **Disabled**.

## Above 4G Decoding

Select **Enabled** to decode a PCI device that supports 64-bit in the space above 4G Address. The options are **Enabled** and **Disabled**.



**Note** Available if the system supports 64-bit PCI decoding.

## SR-IOV Support

Select **Enabled** for Single-Root IO Virtualization support. The options are **Enabled** and **Disabled**.



**Note** Available if the system supports Single-Root Virtualization.

## Maximum Payload

Select **Auto** for the system BIOS to automatically set the maximum payload value for a PCI-E device to enhance system performance. The options are **Auto**, **128 Bytes** and **256 Bytes**.

## Maximum Read Request

Select **Auto** for the system BIOS to automatically set the maximum size for a read request for a PCI-E device to enhance system performance. The options are **Auto**, **128 Bytes**, **256 Bytes**, **512 Bytes**, **1024 Bytes**, **2048 Bytes**, and **4096 Bytes**.

## ASPM Support

Use this item to set the Active State Power Management (ASPM) level for a PCI-E device. Select **Auto** for the system BIOS to automatically set the ASPM level based on the system configuration. Select **Disabled** to disable ASPM support. The options are **Disabled** and **Auto**.



**Caution** Enabling ASPM support may cause some PCI-E devices to fail.

## MMIOHBase

Use this item to select the base memory size according to memory-address mapping for the IO hub. The base memory size must be between 4032G to 4078G. The options are **56T**, **48T**, **24T**, **512G**, and **256G**.

## MMIO High Size

Use this item to select the high memory size according to memory-address mapping for the IO hub. The options are **256G**, **128G**, **512G**, and **1024G**.

RSC-R2UW-2E8R Slot1 PCI-E x8 (OPROM)/RSC-R2UW-4E8 Slot4 PCI-E x8 (OPROM)/RSC-R2UW-4E8 Slot3 PCI-E x8 (OPROM)/RSC-R2UW-4E8 Slot1 PCI-E x8 (OPROM)/ RSC-R2UW-4E8 Slot2 PCI-E x8 (OPROM)

Select **Enabled** to enable Option ROM support to boot the computer using a device installed on the slot specified by the user. The options are **Disabled**, **Legacy**, and **EFI**.

## Onboard LAN OPROM

Use this option to select the type of device installed in LAN Port used for system boot. The default setting for LAN OPROM is **EFI**.

## VGA Priority

Use this item to select the graphics device to be used as the primary video display at bootup. The options are Onboard and **Offboard**.

## Network Stack

Select **Enabled** to enable PXE (Preboot Execution Environment) or UEFI (Unified Extensible Firmware Interface) for network stack support. The options are **Enabled** and **Disabled**.

## Ipv6 PXE Support

Select **Enabled** to enable Ipv6 PXE (Preboot Execution Environment) for boot support. If this feature is set to **Disabled**, Ipv6 PXE boot option will not be supported. The options are **Enabled** and **Disabled**.



**Note** Available when Network Stack is set to **Enabled**.

## Super IO Configuration

Super IO Chip AST2400

### Serial Port 1 Configuration/Serial Port 2 Configuration

Select **Enabled** to enable the onboard serial port specified by the user. The options are **Enabled** and **Disabled**.

## Device Settings

This item displays the base I/O port address and the Interrupt Request address of a serial port specified by the user.

### Change Port 1 Settings/Change Port 2 Settings

This feature specifies the base I/O port address and the Interrupt Request address of Serial Port 1 or Serial Port 2. Select **Auto** for the BIOS to automatically assign the base I/O and IRQ address to a serial port specified.

The options for Serial Port 1 are **Auto**, (**IO=3F8h; IRQ=4**), (**IO=3F8h; IRQ=3, 4, 5, 6, 7, 9, 10, 11, 12**), (**IO=2F8h; IRQ=3, 4, 5, 6, 7, 9, 10, 11, 12**); (**IO=3E8h; IRQ=3, 4, 5, 6, 7, 9, 10, 11, 12**), and (**IO=2E8h; IRQ=3, 4, 5, 6, 7, 9, 10, 11, 12**).

The options for Serial Port 2 are **Auto**, (**IO=3F8h; IRQ=4**), (**IO=3F8h; IRQ=3, 4, 5, 6, 7, 9, 10, 11, 12**), (**IO=2F8h; IRQ=3, 4, 5, 6, 7, 9, 10, 11, 12**); (**IO=3E8h; IRQ=3, 4, 5, 6, 7, 9, 10, 11, 12**), and (**IO=2E8h; IRQ=3, 4, 5, 6, 7, 9, 10, 11, 12**).

## Serial Port 2 Attribute

Select **SOL** to use COM Port 2 as a Serial\_Over\_LAN (SOL) port for console redirection. The options are **COM** and **SOL**.

## Serial Port Console Redirection

### COM 1 Console Redirection

Select **Enabled** to enable COM Port 1 for Console Redirection, which will allow a client machine to be connected to a host machine at a remote site for networking. The options are **Enabled** and **Disabled**.

If the item above set to **Enabled**, the following items will become available for configuration:

### COM1 Console Redirection

#### Terminal Type

This feature allows the user to select the target terminal emulation type for Console Redirection. Select **VT100** to use the ASCII Character set. Select **VT100+** to add color and function key support. Select **ANSI** to use the Extended ASCII Character Set. Select **VT-UTF8** to use UTF8 encoding to map Unicode characters into one or more bytes. The options are **ANSI**, **VT100**, **VT100+**, and **VT-UTF8**.

#### Bits Per second

Use this item to set the transmission speed for a serial port used in Console Redirection. Make sure that the same speed is used in the host computer and the client computer. A lower transmission speed may be required for long and busy lines. The options are **9600**, **19200**, **38400**, **57600** and **115200** (bits per second).

#### Data Bits

Use this feature to set the data transmission size for Console Redirection. The options are **7 (Bits)** and **8 (Bits)**.

#### Parity

A parity bit can be sent along with regular data bits to detect data transmission errors. Select **Even** if the parity bit is set to 0, and the number of 1s in data bits is even. Select **Odd** if the parity bit is set to 0, and the number of 1s in data bits is odd. Select **None** if you do not want to send a

parity bit with your data bits in transmission. Select **Mark** to add a mark as a parity bit to be sent along with the data bits. Select **Space** to add a Space as a parity bit to be sent with your data bits. The options are **None**, **Even**, **Odd**, **Mark** and **Space**.

### Stop Bits

A stop bit indicates the end of a serial data packet. Select **1 Stop Bit** for standard serial data communication. Select **2 Stop Bits** if slower devices are used. The options are **1** and **2**.

### Flow Control

Use this item to set the low control for Console Redirection to prevent data loss caused by buffer overflow. Send a "Stop" signal to stop sending data when the receiving buffer is full. Send a "Start" signal to start sending data when the receiving buffer is empty. The options are **None** and **Hardware RTS/CTS**.

### VT-UTF8 Combo Key Support

Select **Enabled** to enable VT-UTF8 Combination Key support for ANSI/VT100 terminals. The options are **Enabled** and **Disabled**.

### Recorder Mode

Select **Enabled** to capture the data displayed on a terminal and send it as text messages to a remote server. The options are **Disabled** and **Enabled**.

### Resolution 100x31

Select **Enabled** for extended-terminal resolution support. The options are **Disabled** and **Enabled**.

### Legacy OS Redirection Resolution

Use this item to select the number of rows and columns used in Console Redirection for legacy OS support. The options are **80x24** and **80x25**.

### Putty KeyPad

This feature selects Function Keys and KeyPad settings for Putty, which is a terminal emulator designed for the Windows OS. The options are **VT100**, **LINUX**, **XTERMR6**, **SCO**, **ESCN**, and **VT400**.

### Redirection After BIOS Post

Use this feature to enable or disable legacy Console Redirection after BIOS POST. When set to **Bootloader**, legacy Console Redirection is disabled before booting the OS. When set to **Always Enable**, legacy Console Redirection remains enabled when booting the OS. The options are **Always Enable** and **Bootloader**.

## SOL/COM2 Console Redirection

Select **Enabled** to use the SOL port for Console Redirection. The options are **Enabled** and **Disabled**.

If the item above set to **Enabled**, the following items will become available for user's configuration:

## SOL/COM2 Console Redirection Settings

Use this feature to specify how the host computer will exchange data with the client computer, which is the remote computer used by the user.

### Terminal Type

Use this feature to select the target terminal emulation type for Console Redirection. Select **VT100** to use the ASCII Character set. Select **VT100+** to add color and function key support. Select **ANSI** to use the Extended ASCII Character Set. Select **VT-UTF8** to use UTF8 encoding to map Unicode characters into one or more bytes. The options are **ANSI**, **VT100**, **VT100+**, and **VT-UTF8**.

### Bits Per second

Use this feature to set the transmission speed for a serial port used in Console Redirection. Make sure that the same speed is used in the host computer and the client computer. A lower transmission speed may be required for long and busy lines. The options are **9600**, **19200**, **38400**, **57600** and **115200** (bits per second).

### Data Bits

Use this feature to set the data transmission size for Console Redirection. The options are **7 (Bits)** and **8 (Bits)**.

### Parity

A parity bit can be sent along with regular data bits to detect data transmission errors. Select **Even** if the parity bit is set to 0, and the number of 1s in data bits is even. Select **Odd** if the parity bit is set to 0, and the number of 1's in data bits is odd. Select **None** if you do not want to send a parity bit with your data bits in transmission. Select **Mark** to add a mark as a parity bit to be sent along with the data bits. Select **Space** to add a Space as a parity bit to be sent with your data bits. The options are **None**, **Even**, **Odd**, **Mark** and **Space**.

### Stop Bits

A stop bit indicates the end of a serial data packet. Select **1 Stop Bit** for standard serial data communication. Select **2 Stop Bits** if slower devices are used. The options are **1** and **2**.

### Flow Control

Use this feature to set the low control for Console Redirection to prevent data loss caused by buffer overflow. Send a "Stop" signal to stop sending data when the receiving buffer is full. Send

a "Start" signal to start sending data when the receiving buffer is empty. The options are **None** and **Hardware RTS/CTS**.

### VT-UTF8 Combo Key Support

Select **Enabled** to enable VT-UTF8 Combination Key support for ANSI/VT100 terminals. The options are **Enabled** and **Disabled**.

### Recorder Mode

Select **Enabled** to capture the data displayed on a terminal and send it as text messages to a remote server. The options are **Disabled** and **Enabled**.

### Resolution 100x31

Select **Enabled** for extended-terminal resolution support. The options are **Disabled** and **Enabled**.

### Legacy OS Redirection Resolution

Use this feature to select the number of rows and columns used in Console Redirection for legacy OS support. The options are **80x24** and **80x25**.

### Putty KeyPad

This feature selects Function Keys and KeyPad settings for Putty, which is a terminal emulator designed for the Windows OS. The options are **VT100**, **LINUX**, **XTERMR6**, **SCO**, **ESCN**, and **VT400**.

### Redirection After BIOS Post

Use this feature to enable or disable legacy Console Redirection after BIOS POST. When set to **Bootloader**, legacy Console Redirection is disabled before booting the OS. When set to **Always Enable**, legacy Console Redirection remains enabled when booting the OS. The options are **Always Enable** and **Bootloader**.

### Serial Port for Out-of-Band Management/Windows Emergency Management Services (EMS)

The submenu allows the user to configure Console Redirection settings to support Out-of-Band Serial Port management.

### EMS (Emergency Management Services) Console Redirection

Select **Enabled** to use a COM port selected by the user for EMS Console Redirection. The options are **Enabled** and **Disabled**.

If the item above set to **Enabled**, the following items will become available for user's configuration:

## EMS Console Redirection Settings

This feature allows the user to specify how the host computer will exchange data with the client computer, which is the remote computer used by the user.

### Out-of-Band Management Port

The feature selects a serial port in a client server to be used by the Microsoft Windows Emergency Management Services (EMS) to communicate with a remote host server. The options are **COM1** and **COM2/SOL**.

### Terminal Type

Use this feature to select the target terminal emulation type for Console Redirection. Select **VT100** to use the ASCII character set. Select **VT100+** to add color and function key support. Select **ANSI** to use the extended ASCII character set. Select **VT-UTF8** to use UTF8 encoding to map Unicode characters into one or more bytes. The options are **ANSI**, **VT100**, **VT100+**, and **VT-UTF8**.

### Bits Per Second

This item sets the transmission speed for a serial port used in Console Redirection. Make sure that the same speed is used in the host computer and the client computer. A lower transmission speed may be required for long and busy lines. The options are **9600**, **19200**, **57600**, and **115200** (bits per second).

### Flow Control

Use this item to set the low control for Console Redirection to prevent data loss caused by buffer overflow. Send a "Stop" signal to stop sending data when the receiving buffer is full. Send a "Start" signal to start sending data when the receiving buffer is empty. The options are **None**, **Hardware RTS/CTS**, and **Software Xon/Xoff**.

The setting for each these features is displayed:

Data Bits, Parity, Stop Bits

## Trusted Computing



**Note** Available when a TPM device is installed and detected by the BIOS.

## Configuration

### Security Device Support

If this feature and the TPM jumper on the motherboard are both set to **Enabled**, onboard security devices will be enabled for TPM support to enhance data integrity and network security. Please reboot the system for a change on this setting to take effect. The options are **Enabled** and **Disabled**.

## TPM State

Select **Enabled** to use TPM (Trusted Platform Module) settings to enhance system data security. Please reboot your system for any change on the TPM state to take effect. The options are **Disabled** and **Enabled**.

## Pending Operation

Use this item to schedule a TPM-related operation to be performed by a security device for system data integrity. Your system will reboot to carry out a pending TPM operation. The options are **0**, **Enable Take Ownership**, **Disable Take Ownership**, and **TPM Clear**.



**Note** Your system will reboot to carry out a pending TPM operation.

## Current Status Information

This item displays the status of the TPM support on this motherboard.

# ACPI Settings

## WHEA Support

Select **Enabled** to support the Windows Hardware Error Architecture (WHEA) platform and provide a common infrastructure for the system to handle hardware errors within the Windows OS environment to reduce system crashes and to enhance system recovery and health monitoring. The options are **Enabled** and **Disabled**.

# Event Logs

---

Use this feature to configure Event Log settings.

## Change SMBIOS Event Log Settings

This feature allows the user to configure SMBIOS Event settings.

## Enabling/Disabling Options

### SMBIOS Event Log

Change this item to enable or disable all features of the SMBIOS Event Logging during system boot. The options are **Enabled** and **Disabled**.

## Runtime Error Logging Support

Select **Enabled** to support Runtime Error Logging. The options are **Enable** and **Disable**. If this item is set to **Enable**, the following item will be available for configuration:



## Memory Corrected Error Enabling

Select **Enable** for the BIOS to correct a memory error if it is correctable. The options are **Enable** and **Disable**.



**Note** Available when the item above Runtime Error Logging Support is set to **Enable**.

## PCI-Ex (PCI-Express) Error Enable

Select **Yes** for the BIOS to correct errors occurred in the PCI-E slots. The options are **Yes** and **No**.

## Memory Correctable Error Threshold

Use this item to enter the threshold value for correctable memory errors. The default setting is **10**.

## Erasing Settings

### Erase Event Log

Select **Enabled** to erase all error events in the SMBIOS (System Management BIOS) log before an event logging is initialized at bootup. The options are **No** and **Yes**.

### When Log is Full

Select **Erase Immediately** to immediately erase all errors in the SMBIOS event log when the event log is full. Select **Do Nothing** for the system to do nothing when the SMBIOS event log is full. The options are **Do Nothing** and **Erase Immediately**.

## SMBIOS Event Log Standard Settings

### Log System Boot Event

Select **Enabled** to log system boot events. The options are **Disabled** and **Enabled**.

### MECI (Multiple Event Count Increment)

Enter the increment value for the multiple event counter. Enter a number between 1 to 255. The default setting is **1**.

### METW (Multiple Event Count Time Window)

This item is used to determine how long (in minutes) should the multiple event counter wait before generating a new event log. Enter a number between 0 to 99. The default setting is **60**.



**Note** Please reboot the system for the changes to take effect.

### View System Event Log

This item allows the user to view the event in the system event log. Select this item and press <Enter> to view the status of an event in the log.

Date/Time/Sensor/Type

# IPMI

---

Use this feature to configure Intelligent Platform Management Interface (IPMI) settings.

## IPMI Firmware Revision

This item indicates the IPMI firmware revision used in your system.

## IPMI Status

This item indicates the status of the IPMI firmware installed in your system.

## System Event Log

### Enabling/Disabling Options

#### SEL Components

Select **Enabled** for all system event logging at bootup. The options are **Enabled** and **Disabled**.

### Erasing Settings

#### Erase SEL

Select **Yes, On next reset** to erase all system event logs upon next system reboot. Select **Yes, On every reset** to erase all system event logs upon each system reboot. Select **No** to keep all system event logs after each system reboot. The options are **No, Yes, On next reset**, and **Yes, On every reset**.

#### When SEL is Full

This feature allows the user to decide what the BIOS should do when the system event log is full. Select **Erase Immediately** to erase all events in the log when the system event log is full. The options are **Do Nothing** and **Erase Immediately**.



**Note** After making changes on a setting, be sure to reboot the system for the changes to take effect.

## BMC Network Configuration

The following items will be displayed:

### IPMI LAN Selection

This item displays the IPMI LAN setting. The default setting is **Failover**.

### IPMI Network Link Status

This item displays the IPMI Network Link status. The default setting is **Shared LAN**.

## Update IPMI LAN Configuration

Select **Yes** for the BIOS to implement all IP/MAC address changes at the next system boot. The options are **No** and **Yes**.

## Configuration Address Source

This feature allows the user to select the source of the IP address for this computer. If **Static** is selected, you will need to know the IP address of this computer and enter it to the system manually in the field. If **DHCP** is selected, the BIOS will search for a DHCP (Dynamic Host Configuration Protocol) server in the network that is attached to and request the next available IP address for this computer. The options are **DHCP** and **Static**.

The following items are assigned IP addresses automatically if DHCP is selected, or they can be configured manually if Static is selected.

### Station IP Address

This item displays the Station IP address for this computer. This should be in decimal and in dotted quad form (i.e., 192.168.10.253).

### Subnet Mask

This item displays the sub-network that this computer belongs to. The value of each three-digit number separated by dots should not exceed 255.

### Station MAC Address

This item displays the Station MAC address for this computer. Mac addresses are 6 two-digit hexadecimal numbers.

### Gateway IP Address

This item displays the Gateway IP address for this computer. This should be in decimal and in dotted quad form (i.e., 192.168.10.253).

## Security Settings

---

This menu allows the user to configure the following security settings for the system.

### Password Check

Select **Setup** for the system to check for a password at Setup. Select **Always** for the system to check for a password at bootup or upon entering the BIOS Setup utility. The options are **Setup** and **Always**.

### Administrator Password

Use this feature to set the administrator password which is required to enter the BIOS setup utility. The length of the password should be from 3 characters to 20 characters long.

## Secure Boot Menu

Customizable secure boot settings.

### Secure Boot

Options are **Enabled** and **Disabled**.

### Secure Boot Mode

Options are **Standard** and **Custom**.

### CSM Support

Options are **Enabled** and **Disabled**.

### Key Management

Enables experienced users to modify Secure Boot Variables.

## Boot Settings

---

Use this feature to configure Boot Settings:

### Setup Prompt Timeout

Use this item to indicate the length of time (the number of seconds) for the BIOS to wait before rebooting the system when the setup activation key is pressed. Enter the value of 65535(0xFFFF) for the BIOS to wait indefinitely. The default setting is **1**.

### Boot Mode Select

Use this item to select the type of device that the system is going to boot from. The options are **Legacy**, **UEFI**, and **Dual**. The default setting is **UEFI**.

### Fixed Boot Order Priorities

This option prioritizes the order of bootable devices that the system to boot from. Press <Enter> on each entry from top to bottom to select devices.

- UEFI Boot Order #1
- UEFI Boot Order #2
- UEFI Boot Order #3
- UEFI Boot Order #4
- UEFI Boot Order #5
- UEFI Boot Order #6
- UEFI Boot Order #7
- UEFI Boot Order #8

## Add New Boot Option

This feature allows the user to add a new boot option to system boot priority features.

### Add Boot Option

Use this item to specify the name of the driver that the new boot option is added to.

### Path for Boot Option

This item is used to specify the path to the driver that the new boot option is added to. The format for the path is `fsx:\path\filename\efi`.

## Boot Option File Path

### Create

After the driver option name and the file path are set, press <Enter> to enter to submenu and click OK to create the new boot option drive.

### Delete Boot Option

Use this item to select a boot device to delete from the boot priority list. Select the target boot device to delete.

## Save & Exit

---

Select the Save & Exit tab from the BIOS setup utility screen to enter the Exit BIOS Setup screen.

### Discard Changes and Exit

Select this option to quit the BIOS Setup without making any permanent changes to the system configuration, and reboot the computer. Select **Discard Changes and Exit** from the Exit menu and press <Enter>.

### Save Changes and Reset

When you have completed the system configuration changes, select this option to leave the BIOS setup utility and reboot the computer, so the new system configuration parameters can take effect. Select **Save Changes and Exit** from the Exit menu and press <Enter>.

## Save Options

### Save Changes

After completing the system configuration changes, select this option to save the changes you have made. This will not reset (reboot) the system.

## Discard Changes

Select this option and press <Enter> to discard all the changes and return to the AMI BIOS utility Program.

## Restore Defaults

To set this feature, select **Restore Defaults** from the Exit menu and press <Enter>. These are factory settings designed for maximum system performance, but not for maximum stability.

## Save As User Defaults

To set this feature, select Save as User Defaults from the Exit menu and press <Enter>. This enables the user to save any changes to the BIOS setup for future use.

## Restore User Defaults

To set this feature, select Restore User Defaults from the Exit menu and press <Enter>. Use this feature to retrieve user-defined settings that were saved previously.

## Boot Override

This feature allows the user to override the Boot Option Priorities sequence in the Boot menu, and immediately boot the system with another device specified by the user. This is a one-time override.

# BIOS Error Beep Codes

---

Errors may occur during the Power-On Self-Test (POST) routines, which are performed each time the system is powered on.

**Non-fatal errors** are those which, in most cases, allow the system to continue the boot-up process. The error messages normally appear on the screen.

**Fatal errors** will not allow the system to continue to boot-up. If a fatal error occurs, consult with your system manufacturer about possible repairs.

These fatal errors are usually communicated through a series of audible beeps. The numbers on the fatal error list correspond to the number of beeps for the corresponding error.

**Table 2-1.** BIOS Error Beep Codes

Beep Code	Error Message	Description
One beep	Refresh	Circuits have been reset. (Ready to power up.)
Five short beeps and one long beep	Memory error	No memory is detected in the system

**Table 2-1.** BIOS Error Beep Codes (Continued)

Beep Code	Error Message	Description
Eight beeps	Display memory read/write error	Video adapter missing or with faulty memory
OH LED On	System OH	System Overheat

## OS Reinstallation and Recovery



**Caution** Recovering the OS using the hard drive-based recovery or the OS recovery media erases the contents of your hard disk. Before recovering the OS, back up any files you want to keep.

The RMC-8357 includes a preinstalled OS from the factory. The RMC-8357 also includes two methods of restoring/reinstalling the OS to your system.

- Hard drive-based recovery stores a factory backup on a separate portion of your hard drive, allowing you to restore your server without additional media.
  - This option is not available on systems with Windows Server operating systems preinstalled.



**Note** The hard drive recovery hot key is <F4>. To access the hard drive-based recovery tool, press and hold <F4> when video first appears during the boot process.

- The RMC-8357 also ships with an OS recovery media you can use to reinstall your operating system onto your hard drive.  
If you need to reinstall your operating system, you can use the included OS recovery media. Boot the RMC-8357 using the OS recovery media to recover the OS.



**Note** You also may need to update or reinstall software after using the OS reinstallation media to recover your OS. The OS reinstallation media may contain drivers that are older or newer than the factory-installed version of the OS and may not contain the latest RAID drivers. To ensure you have the latest drivers, go to [www.intel.com](http://www.intel.com) and install the Intel Rapid Storage Technology (Intel RST) RAID software package.

# Cleaning

---



**Caution** *Always* disconnect the AC power cable before cleaning or servicing the chassis.

## Exterior Cleaning



**Caution** Avoid getting moisture inside the chassis during exterior cleaning, especially through the top vents.

Do *not* wash the front- or rear-panel connectors or switches. Cover these components while cleaning the chassis.

Do *not* use harsh chemical cleaning agents; they may damage the chassis. Avoid chemicals that contain benzene, toluene, xylene, acetone, or similar solvents.

Clean the exterior surfaces of the chassis with a dry lint-free cloth or a soft-bristle brush. Do *not* use abrasive compounds on any part of the chassis.

## Rack Mounting

---



**Caution** When mounting the equipment in the rack, do not create a hazardous condition due to uneven mechanical loading.

The RMC-8357 rack mounting hardware includes:

- One pair of inner slides to be installed on the chassis.
- One pair of outer slides to be installed in the rack.
- Two pairs of brackets (4 in. and 12 in.) for attaching the outer slides to racks of different depths.
- Bag of assorted fasteners.

## Installing the Inner Slides

Install the inner slides to the RMC-8357 as shown in Figure 2-1.



**Note** The following figure shows an example controller that may differ from your product.



**Figure 2-1.** Installing Inner Slides

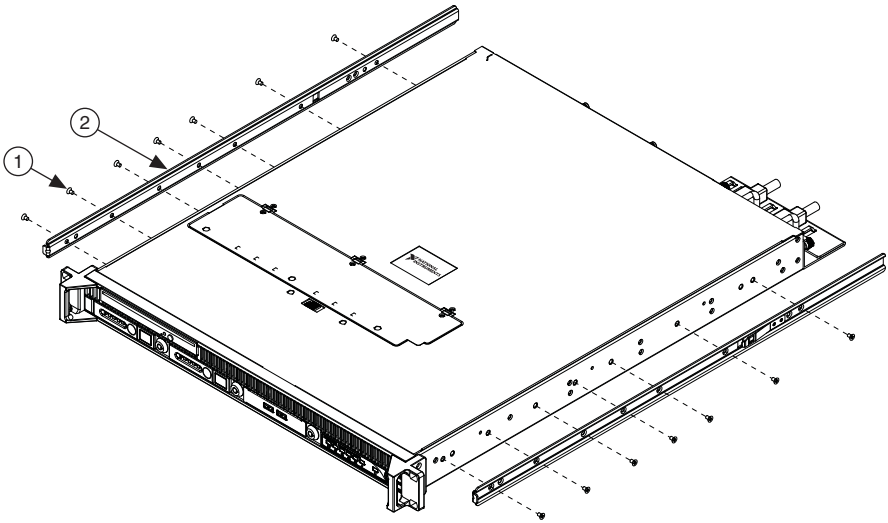

1 Retaining Screw (x14)

2 Inner Slide

# Installing the Slide Mounting Brackets in the Rack

Install the slide mounting brackets in the rack as shown in Figure 2-2.

**Figure 2-2.** Installing Slide Mounting Brackets in Rack

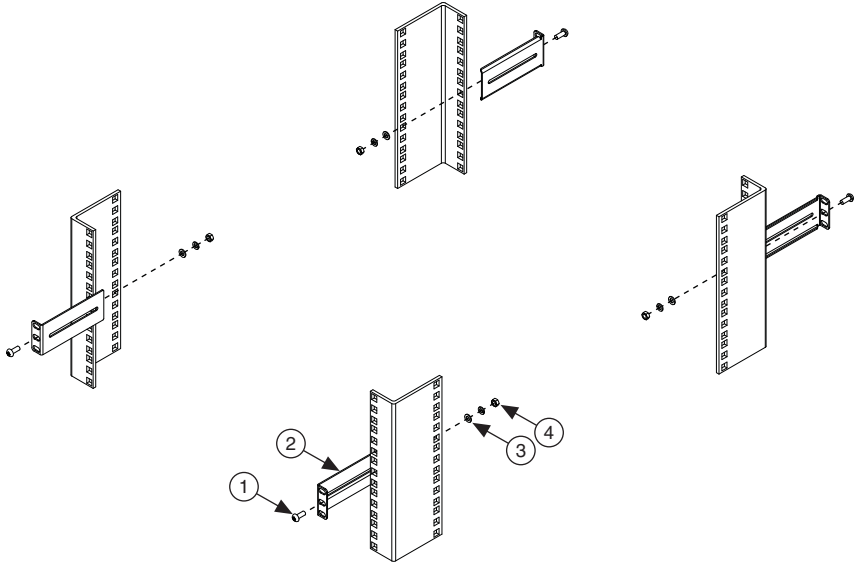

- |   |                             |   |             |
|---|-----------------------------|---|-------------|
| 1 | Retaining Screw (x4)        | 3 | Washer (x8) |
| 2 | Slide Mounting Bracket (x4) | 4 | Nut (x4)    |

## Installing the Outer Slides in the Rack

Install the outer slides in the rack as shown in Figure 2-3.

**Figure 2-3.** Installing Outer Slides in Rack

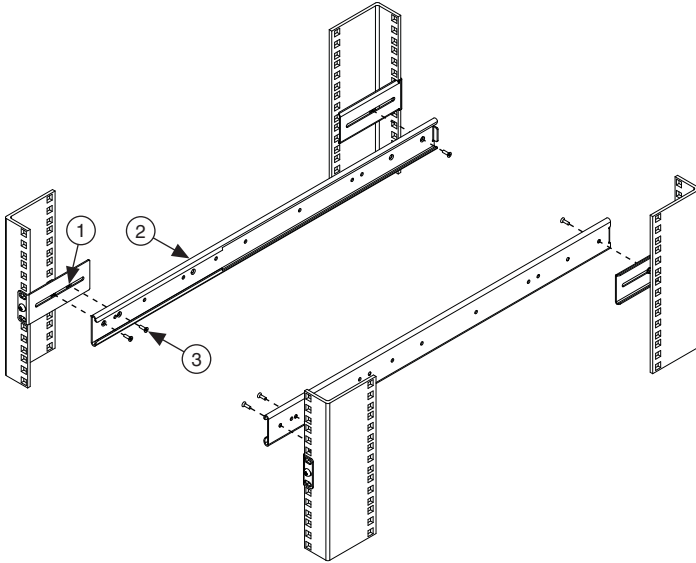

1 Nut (x6)

2 Outer Slide

3 Retaining Screw (x6)

## Installing the Chassis into the Rack

Push the inner slides, attached to the chassis, into the grooves of the outer slides in the rack and slide the RMC-8357 into the rack, as shown in Figure 2-4.



**Note** The following figure shows an example controller that may differ from your product.

**Figure 2-4.** Installing RMC-8357 in Rack

---

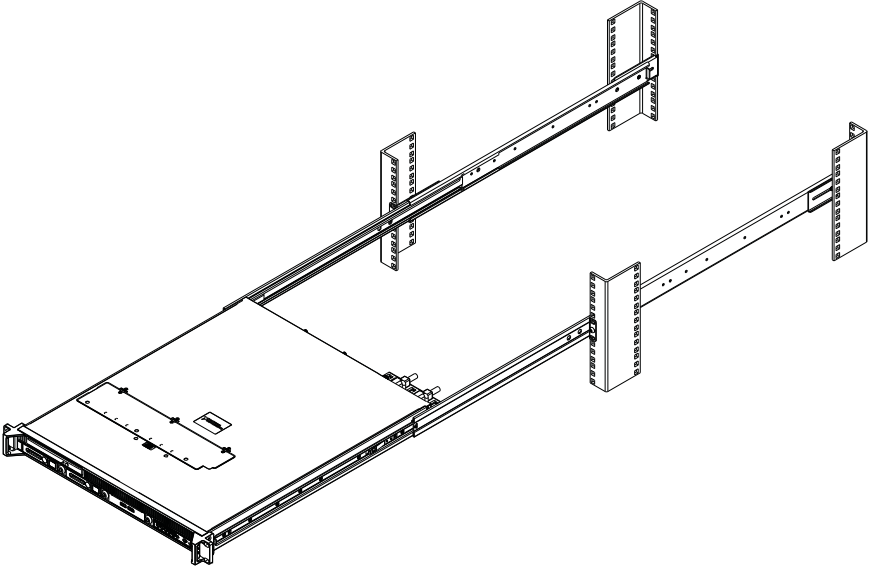

# I/O Information

This chapter describes the RMC-8357 I/O connectors.

## Front Panel Connectors

Table 3-2 lists various peripherals and their corresponding RMC-8357 external connectors, bus interfaces, and functions.

**Table 3-1.** RMC-8357 Front Panel Peripherals Overview

Peripheral	External Connector	Description
USB	USB 4-pin Series A stacked receptacle	USB 3.0 capable

## Rear Panel Connectors

Table 3-2 lists various peripherals and their corresponding RMC-8357 external connectors, bus interfaces, and functions.

**Table 3-2.** RMC-8357 Rear Panel Peripherals Overview

Peripheral	External Connector	Description
Keyboard	USB	USB-style keyboard
Mouse	USB	USB-style mouse
USB	USB 4-pin Series A stacked receptacles	USB 2.0 capable
USB	USB 4-pin Series A stacked receptacles	USB 3.0 capable
IPMI	IPMI dedicated LAN	Not supported
Serial	COM1 (9-pin DSUB) COM2 (9-pin DSUB)	16550 RS-232 serial ports
Video	VGA (15-pin DSUB)	Onboard graphics controller
Ethernet	LAN (RJ45)	10/100/1000 Ethernet connection
Ethernet	LAN (RJ45)	10/100/1000 Ethernet connection

Figure 3-1 shows the rear panel layout of the RMC-8357.

**Figure 3-1. Rear Panel of the RMC-8357**

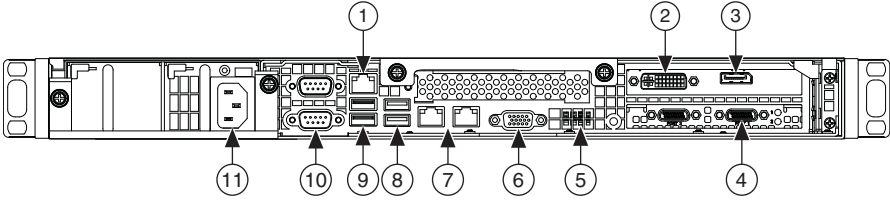

- |                                  |                    |
|----------------------------------|--------------------|
| 1 IPMI Management Port           | 7 LAN Ports        |
| 2 DVI Port                       | 8 USB 3.0 Ports    |
| 3 DisplayPort                    | 9 USB 2.0 Ports    |
| 4 MXI x1 Ports                   | 10 Serial Ports    |
| 5 UID Switch                     | 11 Power Connector |
| 6 VGA Port (Disabled By Default) |                    |

## Universal Serial Bus

Figure 3-2 shows the location and pinouts for the Universal Serial Bus (USB) connectors on the RMC-8357. Table 3-3 lists and describes the USB connector signals.

**Figure 3-2. USB Connector Location and Pinout**

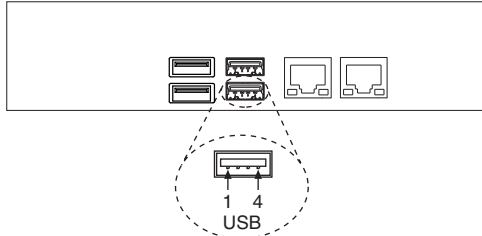

**Table 3-3. USB Connector Signals**

Pin	Signal Name	Signal Description
1	VCC	Cable Power (+5 V)
2	-Data	USB Data-
3	+Data	USB Data+
4	GND	Ground

## Serial

Figure 3-3 shows the location and pinouts for the serial connector on the RMC-8357. Table 3-4 lists and describes the serial connector signal.

**Figure 3-3.** Serial Connector Location and Pinout

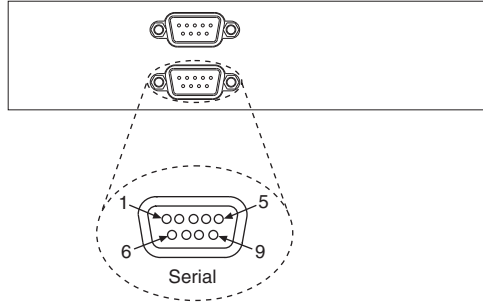

**Table 3-4.** Serial Connector Signals

Pin	Signal Name	Signal Description
1	DCD*	Data Carrier Detect
2	SIN*	Receive Data
3	SOUT*	Transmit Data
4	DTR*	Data Terminal Ready
5	GND	Ground
6	DSR*	Data Set Ready
7	RTS*	Ready to Send
8	CTS*	Clear to Send
9	RI*	Ring Indicator

# VGA

Figure 3-4 shows the location and pinouts for the VGA connector on the RMC-8357. Table 3-5 lists and describes the VGA connector signals.

**Figure 3-4. VGA Connector Location and Pinout**

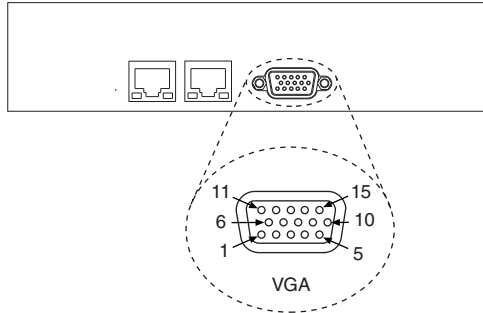

**Table 3-5. VGA Connector Signals**

Pin	Signal Name	Signal Description
1	R	Red
2	G	Green
3	B	Blue
4	NC	Not Connected
5	GND	Ground
6	GND	Ground
7	GND	Ground
8	GND	Ground
9	+5V	5 V
10	GND	Ground
11	NC	Not Connected
12	SD	Serial Data
13	HSync	Horizontal Sync
14	VSynC	Vertical Sync
15	SC	Serial Clock



## Ethernet

Figure 3-5 shows the location and pinouts for the Ethernet connectors on the RMC-8357. Table 3-6 lists and describes the Ethernet connector signals.

**Figure 3-5.** Ethernet Connector Location and Pinout

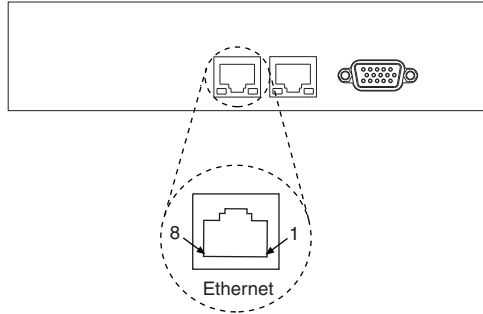

**Table 3-6.** Ethernet Connector Signals

Pin	Signal Name	Signal Description
1	D0P	Differential Pair 0+
2	D0N	Differential Pair 0-
3	D1P	Differential Pair 1+
4	D2P	Differential Pair 2+
5	D2N	Differential Pair 2-
6	D1N	Differential Pair 1-
7	D3P	Differential Pair 3+
8	D3N	Differential Pair 3-

## MXI-Express Connectors

Refer to your MXI-Express hardware user manual for connector information.



**Note** The RMC-8357 BIOS supports only 188 PCI buses by default. For large multichassis systems requiring more than 188 PCI buses, use the NI MXI-Express BIOS Compatibility Software to work around this limitation on Windows. To access the NI MXI-Express BIOS Compatibility Software, search for *MXI-Express BIOS Compatibility Software* at [ni.com/drivers](http://ni.com/drivers).

---

# Common Configuration Questions

This chapter answers common configuration questions you may have when using the RMC-8357.

## General Questions

---

### **What do the LEDs on the RMC-8357 front panel mean?**

The power indicator lights when the main power is turned on. The LAN status LEDs flash to when there is activity on LAN1 and LAN2. The hard drive LED lights when there is hard drive activity on the RMC-8357. For more information, refer to Figure 1-1, [Front View of the RMC-8357](#).

### **How do I check the configuration of the memory, hard drive, time/date, and so on?**

You can view these parameters in the BIOS setup. To enter the BIOS setup, reboot the RMC-8357 and press <Delete> during the memory tests. Refer to the [BIOS Setup](#) section of Chapter 2, [Installation and BIOS Setup](#), for more information.

### **Can I use the internal SATA drive and an external hard drive at the same time?**

Yes.

### **What RAID modes are supported?**

The RMC-8357 supports only RAID 0, 1, and 5.

### **What is the shortcut key to get to the boot menu while the BIOS is going through POST?**

The shortcut key is <F11>.

# Boot Options

---

## What devices can I boot from?

The RMC-8357 can boot from the following devices:

- The internal SATA hard drive
- The internal CD/DVD/Blu-ray drive
- A network PXE server on the same subnet
- An external USB mass storage device



**Note** You should enable Legacy USB support to boot from USB devices. Refer to the *BIOS Setup* section of Chapter 2, *Installation and BIOS Setup*, for more information.

## How do I configure the controller to boot from these devices?

Press <Delete>, enter the BIOS, and select **Boot**. Set the order by device type and set the order for the devices listed within the device type. Refer to *BIOS Setup* in Chapter 2, *Installation and BIOS Setup*, for more information.

# Chassis Configuration

---

## How do I set up the RMC-8357 to work with my PXIe chassis?

Configuration of the PXI system is handled through Measurement & Automation Explorer (MAX), included with the software pre-installed on your RMC-8357. MAX creates the `pxisys.ini` file, which defines the layout and parameters of your PXI system.

The configuration steps for single or multiple-chassis systems are the same. In MAX, select **Help»Help Topics»PXI** to configure your chassis.

The PXI specification allows many combinations of PXIe chassis and system modules. To assist system integrators, the manufacturers of PXIe chassis and system modules must document the capabilities of their products. The minimum documentation requirements are contained in `.ini` files, which consist of ASCII text. System integrators, configuration utilities, and device drivers can use these `.ini` files.

The capability documentation for the chassis is contained in a `chassis.ini` file provided by the chassis manufacturer. The information in this file is combined with information about the system controller to create a single system initialization file called `pxisys.ini` (PXI System Initialization). The RMC-8357 uses MAX to generate the `pxisys.ini` file from the `chassis.ini` file.

Device drivers and other utility software read the `pxisys.ini` file to obtain system information. For detailed information about initialization files, refer to the PXI specification at [www.pxisa.org](http://www.pxisa.org).

---

# Troubleshooting

This chapter answers common troubleshooting questions you may have when using the RMC-8357.

## What if the RMC-8357 does not boot?

Several problems can cause a controller not to boot. Here are some things to look for and possible solutions.

### Things to Notice:

- Which LEDs come on? The power indicator LED should stay lit. The hard disk drive LEDs should blink during boot as the disk is accessed.
- What appears on the display? Does it hang at some particular point (BIOS, Operating System, and so on)? If nothing appears on the screen, try a different monitor. Does your monitor work with a different PC? If it hangs, note the last screen output that you saw for reference when consulting National Instruments technical support.
- What has changed about the system? Did you recently move the system? Was there electrical storm activity? Did you recently add a new module, memory chip, or piece of software?
- Has the system overheated? If the Overheat/FanFail LED is lit, this indicates overheating. Unplug the AC power cord from the controller and allow it to cool down before powering it on again.

### Things to Try:

- Make sure the RMC-8357 is plugged in to a working power source.
- Make sure the monitor is plugged into the DisplayPort or DVI port. The VGA port is disabled by default.
- Remove the power supply and reinsert it.
- Remove any nonessential cables or devices.
- Make sure the CPU and memory modules are properly seated in their slots.
- Recover the hard drive on the RMC-8357. (Refer to the [OS Reinstallation and Recovery](#) section of Chapter 2, [Installation and BIOS Setup](#).)
- Remove memory from unsupported slots.

**My RMC-8357 boots fine until I get to Windows, at which point I cannot read the screen. This may include garbled output, white screen, black screen, or an out of synch message from the monitor.**

This problem usually results from having the video card output set past the limits of the monitor. You will need to boot Windows in Safe Mode. To do this, reboot the RMC-8357. As Windows begins to boot, hold down <F8>. You should now be able to reset the video driver to lower settings. Try setting the resolution to 640 × 480 and the refresh rate to 60 Hz. Once you reboot, you can raise these values again, using the test option in Windows. These settings are accessible through the **Advanced** tab of the **Display** item in the **Control Panel**. Alternately, you can try a different monitor, preferably a newer and larger one.

**My system boots fine as long as a particular module is not in my chassis.**

The most common cause of this is a damaged module. Try the module in a different chassis or with a different controller. Also, remove any external cables or terminal blocks connected to the system. If the module does not work in these cases, it is likely damaged. Contact the module manufacturer for further troubleshooting.

Refer to the KnowledgeBase or product manuals section at [ni.com](http://ni.com) for more information specific to the chassis and module with which you are having difficulties.

# Specifications

This appendix lists the RMC-8357 electrical, mechanical, and environmental specifications.

## Electrical

### AC Input

Input voltage range	100 to 240 VAC
Operating voltage range	90 to 264 VAC
Input frequency	50/60 Hz
Operating frequency range	47 to 63 Hz
Current rating	12 to 6 A max (750 W max single power supply)
Power disconnect	The AC power cable provides main power disconnect. Depressing the front panel power switch enables or inhibits the internal power supply.

### DC Input

Input	23 V to 36 V, 16 A to 8 A $\pm 10\%$
Current rating	+12 V -41 A +5 VSB 0 to 3 A
DC output	500 W (max)



**Note** The connection to a DC mains supply is considered an energy hazard and must not be in an operator access area. The DC product must be located in a Restricted Access Location.



**Caution** Use the DC power cable provided with DC power supplies for VDC input.



**Caution** Using the RMC-8357 in a manner not described in this document may impair the protection the RMC-8357 provides.

## Mainboard

Socket	LGA 2011
Chipset	Xeon E5-2620 v4
Memory slots	Eight 240-pin DIMM DDR4 slots
PCI Express	One PCI Express 3.0 x16 slot and one PCI Express 3.0 x16 slot (half height)
SATA	Four SATA III ports
USB ports	Four USB 3.0 ports, two USB 2.0 ports
Video	VGA port (disabled by default), DVI, DisplayPort, PCIe video graphics card
Serial	Two RS-232 serial port
LAN	Two RJ45 LAN jacks

## CPU

CPU	Xeon E5-2620 v4 Eight Core
Clock speed	2.10 GHz
Max turbo frequency	3.0 GHz
Intel Smart Cache	20 MB
Package	LGA 2011

## Hard Disk Drive

Capacity	Up to four front removeable 2.5 in. drives
Interface	SATA III
Drive options	1 TB 2.5 in. SSD ( NI part number 785672-01)

## Memory

Standard memory configuration	32 GB (4 × 8 GB), DDR4 SDRAM
-------------------------------	------------------------------



**Notes** 8 × 288-pin DDR4 DIMM slots.

Up to 256 GB ECC RDIMM.

RDIMM size: 32 GB, 16 GB, 8 GB, 4 GB.

## Mechanical

Overall dimensions (standard chassis)

Height	1U
Width	432 mm (17.0 in.)
Depth	538.5 mm (21.2 in.)
Depth (including handles)	563.9 mm (22.2 in.)
Weight	8.1 kg (17.8 lbs)

## Shock and Vibration

Mechanical Shock	
Operating	30 g, 11 ms

Test Procedures	Standard
Operating	IEC 68-2-27

## Operational Random

Frequency (Hz)	Vibration Level
5 to 350	0.0002 g <sup>2</sup> /Hz
350 to 500	-3 dB/octave
500	0.00014 g <sup>2</sup> /Hz
Total g <sub>rms</sub> = 0.31	



## Operational Random

Frequency (Hz)	Vibration Level
5 to 100	0.02 g <sup>2</sup> /Hz
100 to 200	-3 dB/octave
200 to 350	0.01 g <sup>2</sup> /Hz
350 to 500	-3 dB/octave
500	0.007 g <sup>2</sup> /Hz
Total g <sub>rms</sub> = 2.46	

## Random Vibration Test Procedures

Test	Standard
Operating	IEC 68-2-64
Non-operating	IEC 68-2-64

## Environmental



**Caution** If installed in a closed or multiunit rack assembly, the rack environment operating ambient temperature may be greater than room ambient temperature. Therefore, install the equipment in an environment compatible with the maximum ambient temperature (T<sub>ma</sub>) the manufacturer specifies.

Operating temperature (Single Xeon)	0 to 50 °C (CPU turbo mode off) (Tested in accordance with IEC 60068-2-1, IEC 60068-2-2. Meets MIL-PRF-28800F Class 3 low temperature limit and MIL-PRF-28800F Class 2 high temperature limit.)
Storage temperature	-40 to 70 °C (Tested in accordance with IEC 60068-2-1 and IEC 60068-2-2. Meets MIL-PRF-28800F Class 3 temperature limits.)
Relative humidity (tested in accordance with IEC 60068-2-56)	
Operating	10 to 90% noncondensing
Nonoperational (storage)	5 to 95% noncondensing

Operating location	Indoor use only
Maximum altitude	2,000 m
Installation Category	II
Pollution Degree	2

## Acoustic Emissions

Sound pressure level (at operator position) < 70 dBA

## Safety

This product is designed to meet the requirements of the following standards of safety for information technology equipment:

- IEC 60950-1, EN 60950-1
- UL 60950-1, CSA 60950-1



**Caution** Overloading the circuits may damage supply wiring. Do not exceed the ratings on the equipment nameplate when connecting equipment to the supply circuit.



**Note** For UL and other safety certifications, refer to the product label or the [Online Product Certification](#) section.

## Online Product Certification

Refer to the product Declaration of Conformity (DoC) for additional regulatory compliance information. To obtain product certifications and the DoC for this product, visit [ni.com/certification](http://ni.com/certification), search by model number or product line, and click the appropriate link in the Certification column.

## Environmental Management

NI is committed to designing and manufacturing products in an environmentally responsible manner. NI recognizes that eliminating certain hazardous substances from our products is beneficial to the environment and to NI customers.

For additional environmental information, refer to the *NI and the Environment* Web page at [ni.com/environment](http://ni.com/environment). This page contains the environmental regulations and directives with which NI complies, as well as other environmental information not included in this document.

## Waste Electrical and Electronic Equipment (WEEE)



**EU Customers** At the end of the product life cycle, all products *must* be sent to a WEEE recycling center. For more information about WEEE recycling centers, National Instruments WEEE initiatives, and compliance with WEEE Directive 2002/96/EC on Waste and Electronic Equipment, visit [ni.com/environment/weee](http://ni.com/environment/weee).

## Battery Replacement and Disposal



**Battery Directive** This device contains a long-life coin cell battery. If you need to replace it, use the Return Material Authorization (RMA) process or contact an authorized National Instruments service representative. For more information about compliance with the EU Battery Directive 2006/66/EC about Batteries and Accumulators and Waste Batteries and Accumulators, visit [ni.com/environment/batterydirective](http://ni.com/environment/batterydirective).

## 电子信息产品污染控制管理办法（中国 RoHS）



**中国客户** National Instruments 符合中国电子信息产品中限制使用某些有害物质指令 (RoHS)。关于 National Instruments 中国 RoHS 合规性信息，请登录 [ni.com/environment/rohs\\_china](http://ni.com/environment/rohs_china)。(For information about China RoHS compliance, go to [ni.com/environment/rohs\\_china](http://ni.com/environment/rohs_china).)

---

## Hardware Configuration

The RMC-8357 uses a Supermicro X10SRW-F motherboard. For detailed information about this motherboard visit [www.supermicro.com](http://www.supermicro.com).

---

# NI Services

NI provides global services and support as part of our commitment to your success. Take advantage of product services in addition to training and certification programs that meet your needs during each phase of the application life cycle; from planning and development through deployment and ongoing maintenance.

To get started, register your product at [ni.com/myproducts](https://ni.com/myproducts).

As a registered NI product user, you are entitled to the following benefits:

- Access to applicable product services.
- Easier product management with an online account.
- Receive critical part notifications, software updates, and service expirations.

Log in to your MyNI user profile to get personalized access to your services.

---

## Services and Resources

- **Maintenance and Hardware Services**—NI helps you identify your systems' accuracy and reliability requirements and provides warranty, sparing, and calibration services to help you maintain accuracy and minimize downtime over the life of your system. Visit [ni.com/services](https://ni.com/services) for more information.
  - **Warranty and Repair**—All NI hardware features a one-year standard warranty that is extendable up to five years. NI offers repair services performed in a timely manner by highly trained factory technicians using only original parts at an NI service center.
  - **Calibration**—Through regular calibration, you can quantify and improve the measurement performance of an instrument. NI provides state-of-the-art calibration services. If your product supports calibration, you can obtain the calibration certificate for your product at [ni.com/calibration](https://ni.com/calibration).
- **System Integration**—If you have time constraints, limited in-house technical resources, or other project challenges, National Instruments Alliance Partner members can help. To learn more, call your local NI office or visit [ni.com/alliance](https://ni.com/alliance).

- **Training and Certification**—The NI training and certification program is the most effective way to increase application development proficiency and productivity. Visit [ni.com/training](https://ni.com/training) for more information.
  - The Skills Guide assists you in identifying the proficiency requirements of your current application and gives you options for obtaining those skills consistent with your time and budget constraints and personal learning preferences. Visit [ni.com/skills-guide](https://ni.com/skills-guide) to see these custom paths.
  - NI offers courses in several languages and formats including instructor-led classes at facilities worldwide, courses on-site at your facility, and online courses to serve your individual needs.
- **Technical Support**—Support at [ni.com/support](https://ni.com/support) includes the following resources:
  - **Self-Help Technical Resources**—Visit [ni.com/support](https://ni.com/support) for software drivers and updates, a searchable KnowledgeBase, product manuals, step-by-step troubleshooting wizards, thousands of example programs, tutorials, application notes, instrument drivers, and so on. Registered users also receive access to the NI Discussion Forums at [ni.com/forums](https://ni.com/forums). NI Applications Engineers make sure every question submitted online receives an answer.
  - **Software Support Service Membership**—The Standard Service Program (SSP) is a renewable one-year subscription included with almost every NI software product, including NI Developer Suite. This program entitles members to direct access to NI Applications Engineers through phone and email for one-to-one technical support, as well as exclusive access to online training modules at [ni.com/self-paced-training](https://ni.com/self-paced-training). NI also offers flexible extended contract options that guarantee your SSP benefits are available without interruption for as long as you need them. Visit [ni.com/ssp](https://ni.com/ssp) for more information.
- **Declaration of Conformity (DoC)**—A DoC is our claim of compliance with the Council of the European Communities using the manufacturer’s declaration of conformity. This system affords the user protection for electromagnetic compatibility (EMC) and product safety. You can obtain the DoC for your product by visiting [ni.com/certification](https://ni.com/certification).

For information about other technical support options in your area, visit [ni.com/services](https://ni.com/services), or contact your local office at [ni.com/contact](https://ni.com/contact).

You also can visit the Worldwide Offices section of [ni.com/niglobal](https://ni.com/niglobal) to access the branch office websites, which provide up-to-date contact information, support phone numbers, email addresses, and current events.

# Glossary

---

Symbol	Prefix	Value
p	pico	$10^{-12}$
n	nano	$10^{-9}$
$\mu$	micro	$10^{-6}$
m	milli	$10^{-3}$
k	kilo	$10^3$
M	mega	$10^6$
G	giga	$10^9$
T	tera	$10^{12}$

## Symbols

° Degrees

W Ohms

% Percent

## A

A Amperes

A/D Analog-to-digital. Most often used as *A/D converter*.

AC Alternating Current

ACPI Advanced Configuration and Power Management Interface

ANSI American National Standards Institute

API Application Programming Interface—A standardized set of subroutines or functions along with the parameters that a program can call.

APIC Advanced Programmable Interrupt Controller

## Glossary

ASCII	American Standard Code for Information Exchange
ASIC	Application-Specific Integrated Circuit
ATA	The specification formulated in the 1980s that defines the IDE drive interface.
<b>B</b>	
B	Bytes
BIOS	Basic Input/Output System—BIOS functions are the fundamental level of any PC or compatible computer. BIOS functions embody the basic operations needed for successful use of the computer's hardware resources.
<b>C</b>	
C	Celsius
CAS	Column Address Strobe
CMOS	Complementary Metal Oxide Semiconductor—A process used in making chips.
COM	Communications port
CPU	Central Processing Unit
CSA	Carrier Serving Area
<b>D</b>	
D/A	Digital-to-analog—Most often used as an abbreviation for a D/A converter (also known as DAC).
DC	Direct Current
DDR	Double Data Rate
DIMM	Dual In-line Memory Module



DMA	Direct Memory Access—A method by which data is transferred between devices and internal memory without intervention of the central processing unit.
DMI	Desktop Management Interface
DRAM	Dynamic RAM (Random Access Memory)—Storage that the computer must refresh at frequent intervals.
<b>E</b>	
ECC	Error-Correcting Code
EDO RAM	Extended Data Output RAM—A type of random access memory (RAM) chip that improves the time to read from memory on faster microprocessors such as the Intel Pentium.
EEPROM	Electrically Erasable Programmable Read Only Memory
EMC	Electromagnetic Compatibility
EMI	Electromagnetic Interference
EPP	Enhanced Parallel Port
<b>F</b>	
FCC	Federal Communications Commission
<b>G</b>	
GB	Gigabytes of memory
GPIO	General Purpose Interface Bus (IEEE 488)
<b>H</b>	
HDD	Hard Disk Drive
Hz	Hertz; cycles per second

I

I/O	Input/output—The techniques, media, and devices used to achieve communication between machines and users.
IDE	Integrated Drive Electronics—Hard disk and built-in controller.
IEEE	Institute of Electrical and Electronics Engineers
IRQ*	Interrupt signal
ISA	Industry Standard Architecture—The original PC bus architecture, specifically the 16-bit AT bus.

K

KB	Kilobytes of memory
----	---------------------

L

LAN	Local Area Network—Communications network that serves users within a confined geographical area. It is made up of servers, workstations, a network operating system, and a communications link.
LCD	Liquid Crystal Display—A display technology using polarizing filters and liquid crystal cells.
LED	Light-emitting diode

M

MAX	Measurement & Automation Explorer
MB	Megabytes of memory
MPS	Multiprocessor Specification
MTBF	Mean Time Between Failure

MTTR	Mean Time to Repair
MXI	Multisystem eXtension Interface

## N

NI-DAQ	The National Instruments software for data acquisition instruments.
NI-VISA	The National Instruments implementation of the VISA standard—An interface-independent software that provides a unified programming interface for VXI, GPIB, and serial instruments.

## P

PCI	Peripheral Component Interconnect. The PCI bus is a high-performance 32-bit or 64-bit bus with multiplexed address and data lines.
PEF	Platform Event Filter
PIO	Programmed Input/Output
POSC	Power On Self Configuration
POST	Power On Self Test
PXI	PCI eXtensions for Instrumentation—An open implementation of CompactPCI that adds electrical features that meet the high-performance requirements of instrumentation applications by providing triggering, local buses, and system clock capabilities. PXI also offers two-way interoperability with CompactPCI products.

## R

RAM	Random Access Memory—The computer's primary workspace.
RAS	Row Address Strobe

## Glossary

RMS	Root Mean Squared
RTC	Real Time Clock—An electronic circuit that maintains the time of day and also can provide timing signals for timesharing operations.

## S

SATA	Serial-ATA. <i>See also</i> <a href="#">ATA</a> .
SCSI	Small Computer System Interface
SDRAM	A form of dynamic RAM memory that is about 20% faster than EDO RAM. SDRAM interleaves two or more internal memory arrays so that while one array is being accessed, the next one is being prepared for access. SDRAM-II is a faster version of SDRAM technology.
SO-DIMM	Small Outline Dual In-line Memory Module
SPD	Serial Presence Detect EEPROM
SRAM	Static RAM—A memory chip that requires power to hold its content. It does not require refresh circuitry as a dynamic RAM chip, but it does take up more space and uses more power.

## U

UDMA	Ultra Direct Memory Access. <i>See also</i> <a href="#">DMA</a> .
USB	Universal Serial Bus

**V**

V	Volts
VGA	Video Graphics Array—The minimum video display standard for all PCs.
VISA	Virtual Instrument Software Architecture—A single interface library for controlling GPIB, VXI, RS232, and other types of instruments. VISA has been standardized by the VXI <i>Plug&amp;Play</i> Systems Alliance.
VME	Versa Module Eurocard
VXI	VME eXtensions for Instrumentation

**W**

W	Watts
WDT	Watchdog Timer

# Index

---

## A

AC power cables (table), 1-1  
acoustic emissions specifications, A-5

## B

BIOS checking settings, 4-1  
boot options, configuring controller, 4-2

## C

cables, power (table), 1-1  
common configuration questions, 4-1  
    boot options, 4-2  
    chassis configuration, 4-2  
    general questions, 4-1  
connectors  
    Ethernet connector and signals, 3-5  
    peripheral expansion overview  
    (table), 3-1  
    serial connector and signals, 3-3  
    Universal Serial Bus (USB) connector  
    and signals, 3-2  
    VGA connector and signals, 3-4  
CPU specifications, A-2

## D

documentation, related, *xiii*

## E

electrical specifications, A-1  
environmental management  
    specifications, A-6  
environmental specifications, A-4  
Ethernet connector and signals, 3-5  
    location and pinout (figure), 3-5  
    signals (table), 3-5  
Ethernet, overview (table), 3-1

## H

hard disk drives specifications, A-2

## I

IDE controller, using SCSI hard drive in  
    addition, 4-1  
inner slides, installing (figure), 2-40  
installation  
    configuration and operation  
    site considerations, 2-2  
    unpacking the RMC-8357, 1-1  
installing RMC-8356, 2-1

## K

key features, 1-2  
keyboard, overview (table), 3-1  
kit contents, 1-1

## L

LEDs, front panel, 4-1

## M

mainboard specifications, A-2  
maintenance of RMC-8356  
    cleaning, exterior, 2-39  
mechanical specifications, A-3  
memory specifications, A-2

## O

outer slides, installing in rack (figure), 2-42  
overview, 1-2

## P

peripheral expansion overview (table), 3-1  
power cables (table), 1-1, 4-2

## R

rack mounting  
    installing chassis into rack, 2-43  
    installing outer slides in rack, 2-42  
    installing slide mounting brackets, 2-41  
rear panel connectors, 3-1  
related documentation, *xiii*

RMC-8356

- chassis cooling considerations, 2-2
- installation, 2-1

RMC-8357

- boot options, 4-2
- chassis configuration, 4-2
- common configuration questions, 4-1
- configuration, hardware, B-1
- connectors, 3-1
  - Ethernet, 3-5
  - serial connector and signals, 3-3
  - Universal Serial Bus (USB)
    - connector and signals, 3-2
  - VGA, 3-4
- description, 1-4
- front panel LEDs, 4-1
- hardware configuration, B-1
- installing in rack (figure), 2-43
- key features, 1-2
- overview, 1-2
- peripheral expansion overview (table), 3-1
- troubleshooting, 5-1
- using with PXI chassis, 4-2

S

- safety specifications, A-5
- serial connector, 3-3
  - connector locations and pinout (figure), 3-3
  - connector signals (table), 3-3
- serial ports, 3-1
  - See also* COM1 and COM2 connectors
- shock and vibration specifications, A-3
- slide mounting brackets, installing in rack (figure), 2-41
- specifications
  - acoustic emissions, A-5
  - CPU, A-2
  - electrical, A-1
  - environmental, A-4
  - environmental management, A-6
  - hard disk drive, A-2
  - mainboard, A-2
  - mechanical, A-3

- memory, A-2
- safety, A-5
- shock and vibration, A-3

T

- troubleshooting
  - controller does not boot, 5-1
  - damaged module, 5-2
  - video display, 5-2

U

- Universal Serial Bus (USB), 3-1
  - connector location and pinout (figure), 3-2
  - connector signals (table), 3-2
  - connectors and signals, 3-2
  - overview (table), 3-1
- unpacking the RMC-8357, 1-1

V

- VGA
  - connector and signals, 3-4
  - connector signals (table), 3-4
  - location and pinout (figure), 3-4
  - overview (table), 3-1
- video, 3-1
  - See also* VGA